

PUCH MOPED

1980 - 1984

Service Manual

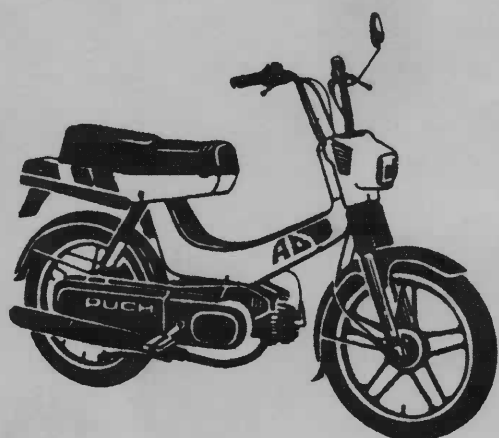

MODELS

THIS SERVICE MANUAL COVERS THE FULL RANGE
OF 1980 THRU 1984 MODELS

MAXI



MAXI LUXE

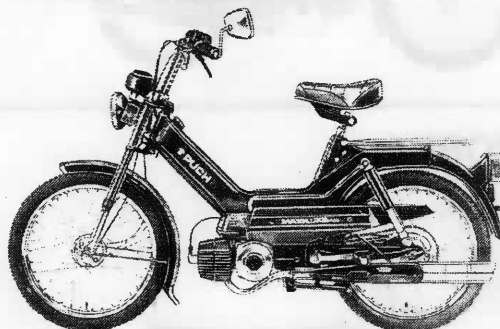

NEWPORT II



SPORT MK II



MAGNUM II

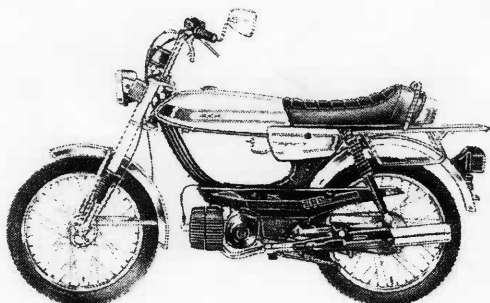

MAGNUM MK II

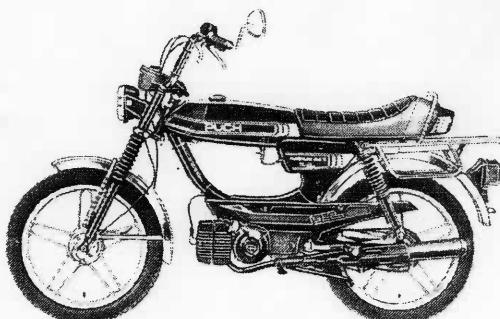

MODELS

MAXI SPORT LS



DART



COBRA



AUSTRO DAIMLER



CONTENTS

LUBRICATION AND MAINTENANCE	6
EXPLODED ENGINE VIEW	19
SPECIAL TOOLS	22
TORQUE SPECIFICATIONS	25
REMOVE ENGINE	26
DISMANTLE ENGINE - 1 SPEED	30
CRANKSHAFT - WRIST PIN	39
PISTON-CYLINDER	41
ASSEMBLE CRANKSHAFT - 1 SPEED	43
ASSEMBLE CLUTCH - 1 SPEED	44
ASSEMBLE ENGINE - 1 SPEED	46
ASSEMBLE/INSTALL ENGINE - 1 SPEED	48
CARBURETOR	54
DISMANTLE ENGINE - 2 SPEED	57
DISMANTLE OIL PUMP DRIVE	63
ASSEMBLE OIL PUMP DRIVE	69
ASSEMBLE ENGINE - 2 SPEED	65
INSTALL ENGINE - 2 SPEED	79
OIL TANK, FUEL TANK	81
FUEL TANK, FUEL TAP	82
FRONT FORK-MAXI, DART, COBRA	83
FRONT FORK-MAGNUM II, XK	87
FRONT FORK-MAGNUM MK II	88
FRONT FORK-AUSTRO DAIMLER	92
SHOCK ABSORBERS-REAR SWING ARM	96
WHEEL ALIGNMENT	97
REAR SWING ARM-AUSTRO DAIMLER	98
BRAKES	99
BRAKES-HUBS	100
HUBS	101
IDLER GEAR - DRIVE SPROCKET	102
TIRE FITTING	103
SPOKING WHEEL	104
BALANCING WHEEL	107
ELECTRICAL EQUIPMENT	108
BREAKER POINTS	110
IGNITION TIMING	111
TROUBLE SHOOTING	112
WIRING DIAGRAM	117
METRIC CONVERSION TABLE	126

LUBRICATION AND MAINTENANCE

ROUTINE MAINTENANCE SCHEDULE:

The required maintenance is clearly described in the following pages, and should be performed at the mileage intervals shown in the following chart.

LUBRICATION & MAINTENANCE CHART

OPERATIONS TO PERFORM	Frequency in miles (km)					
	First	Every				
	300 (480)	600 (960)	900 (1450)	1800 (2900)	3600 (5800)	7200 (11600)
Tire wear and condition	X	X	X	X	X	X
Throttle cable adjustment	X				X	X
Check tire pressure	X	X	X	X	X	X
Check transmission fluid level			X	X	X	X
Clean and lubricate chain	X		X	X	X	X
Clean air filter	X			X	X	X
Change transmission oil	X				X	X
Check spark plug	X		X	X	X	X
Decarbonize engine				X	X	X
Clean exhaust baffle				X	X	X
Retighten screws, nuts	X			X	X	X
Clean fuel valve and lines					X	X
Clean carburetor (filter screen, float chamber)				X	X	X
Check idle speed adjustment	X			X	X	X
Check ignition timing					X	X
Adjust clutch cable	X				X	X
Check brakes (linings every 900)	X		X	X	X	X
Check/lubricate hub bearings					X	X
Steering bearing adjust/lubricate		X	X	X	X	X
Check chain tension/adjust/lubricate	X		X	X	X	X
Lubricate front fork					X	X
Retighten upper fork bridge bolts	X	X	X	X	X	X
Tappet and driver gear on drive shaft/lubricate				X	X	X
Driver gear needle bearing/lubricate					X	X

NOTE: Above time schedule applies to vehicles used on dry paved surfaces with normal operating conditions.



Look for this symbol to point out important safety precautions. It means - Attention! Become alert!

LUBRICATION AND MAINTENANCE

LUBRICATION

Changing Gearbox oil

- 1) Warm up the engine. Stop engine.
- 2) Remove oil drain plug (2) and filler plug (1).
- 3) Drain oil.
- 4) Replace drain plug.
- 5) **1 speed automatic engine:**
Fill with fresh automatic transmission fluid - TYPE F only (oil capacity 5.74 oz (170 cc) to bottom of oil fill hole.
DART, AUSTRO DAIMLER 6.75 oz (200 cc)
- 6) **2 speed automatic engine:**
Fill with fresh automatic transmission fluid - TYPE F only (oil capacity 9.5 oz (280 cc) to bottom of oil level plug.
- 6) Replace oil fill plug.

Cleaning and oiling the chains



Engine should not be running.

Both engine drive and pedal chains should be kept clean. Every few hundred miles wipe chains thoroughly with a cloth, and using a small brush, lubricate with chain oil lubricant. Always keep chains properly adjusted. The proper slack of the drive chain should be $\frac{3}{4}$ in. (2 cm). To adjust the chains, loosen the axle nuts and tighten or loosen the rear adjuster nuts. Once chains are properly adjusted, tighten the axle nuts. Make sure that wheels are always aligned.

Kickstand lubrication

Remove the stand spring (see page 30). Remove three hexagon bolts. Remove stand. Grease both halves of the stand pivot with a good automotive lithium base grease.

Adjusting Screws and Pivot Bolts

Lubricate adjusting screws, tensioning screws and pivot bolts on control levers with a few drops of oil.

MAINTENANCE

Please contact an authorized PUCH Dealer for work you do not wish to carry out yourself. The agent will be pleased to advise and help.

Checking spark plugs

Unscrew spark plug. Insert spark plug into suppressor plug on spark plug wire and touch spark plug electrode to a ground, such as the cylinder head. A blue spark must be visible between the spark plug electrodes when the engine is being turned over. Oily plugs or dirty electrodes do not spark and must be cleaned first with a piece of wood or a steel wire brush. The electrode gap should be from .016 - .020 in. (0.40 to 0.50 mm), adjust by bending the ground electrode. When replacing the spark plug ensure thread matches properly and the plug can be screwed in easily. Never apply force. Screw in plug by hand for 2 to 3 turns before using the spark plug spanner. Torque to 14.5 ft/lb (20 Nm).

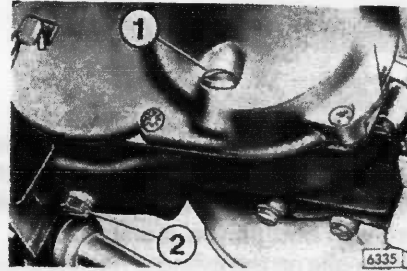

1-SPEED AUTOMATIC

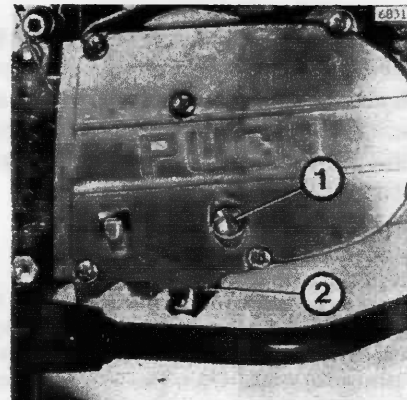

1-SPEED AUTOMATIC

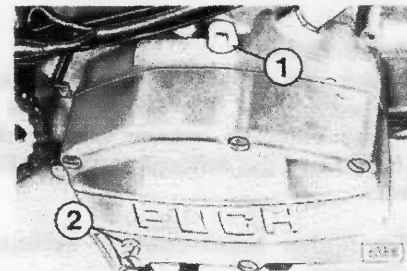

2-SPEED AUTOMATIC

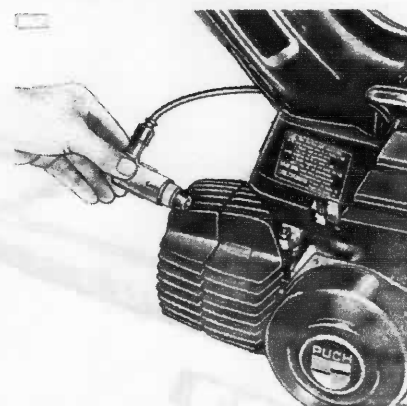

LUBRICATION AND MAINTENANCE

MAINTENANCE

Decarbonizing the engine

Carbon deposits on the cylinder head, piston crown and in the exhaust ports are normal with all two-stroke engines but can eventually lead to trouble if not removed in time. Combustion deposits from oil as well as from fuel must therefore be removed regularly.

Cylinder head and piston crown

Carbon deposits on the cylinder head and piston crown should be removed only with a soft, blunt edged instrument to avoid damage to the alloy casting. Scratching should be avoided since every new scratch will collect more carbon in future use.

Only scaly deposits need be removed from the piston crown. Before refitting the cylinder head, thoroughly remove all carbon deposits and scrapings from the cylinder wall with a non fraying soft cloth and smear the surface lightly with motor oil. Turn over the engine a few times to make sure it cranks easily. Clean the mating surfaces with a clean rag. Replace the cylinder head and tighten the four cylinder head nuts. Be sure to tighten the cylinder head nuts diagonally across from each other before tightening the other two nuts (7 ft/lb/10 Nm).

Exhaust port

In order to clean the exhaust port, remove the exhaust pipe. Crank the engine over (with the spark plug removed to reduce compression) until the piston reaches its lowest point. Remove the oil carbon from the exhaust port. Take care not to damage the piston or cylinder surface. When cleaning the exhaust port, it is also a good idea to clean the muffler.

Cleaning the muffler

Unscrew and pull off the exhaust endpiece. Remove oil-carbon deposits from the inside of the muffler using a scraper. Also carefully remove the oil deposits from the exhaust baffle and the exhaust endpiece. Replace the gasket if necessary.

NOTE: For further break-down of exhaust system refer to diagram.

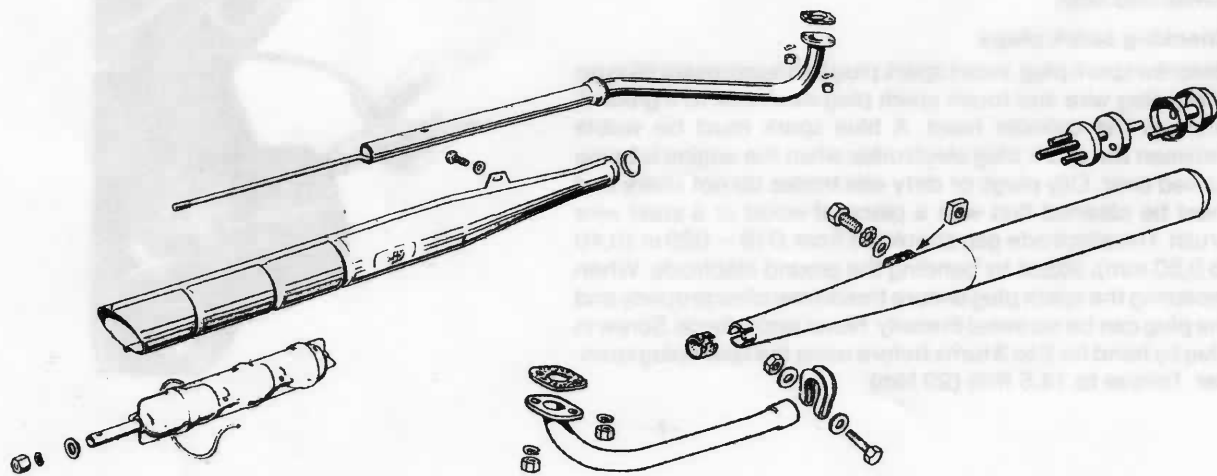
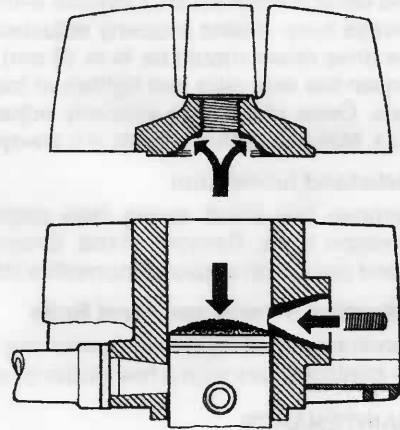

LUBRICATION AND MAINTENANCE

Cleaning the air cleaner – Magnum Series

Remove the left hand chain guard. Remove clamp nut (1). Loosen clamp screw (2) and remove air cleaner assembly from the carburetor. Remove front part of the air cleaner and carefully push out filter screen. Wash filter screen in solvent and allow it to dry thoroughly. Before replacing the filter screen, spray screen with a light layer of engine oil. Reassemble damper pipe, filter screen, and air cleaner assembly.

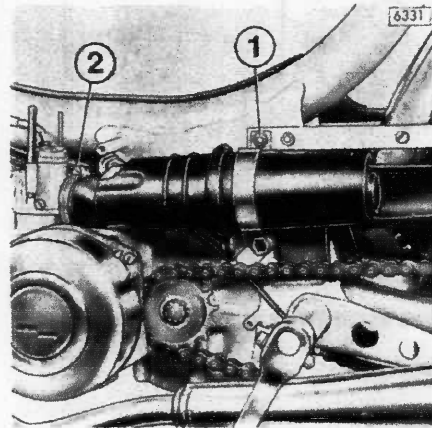
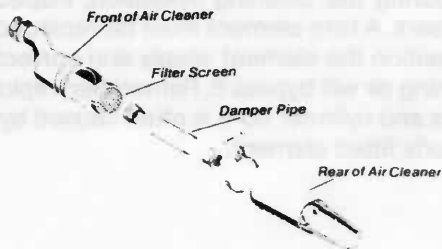

Cleaning the air cleaner – MAXI Series

The air filter on the MAXI is a non-serviceable sealed unit.

Cleaning the air cleaner – AUSTRO DAIMLER Series

Remove the rear mounting screw (1) and hose clamp (2). Slide filter assy. toward the rear and pull out thru frame opening. Dismantle filter.

AUSTRO DAIMLER

air filter assembly

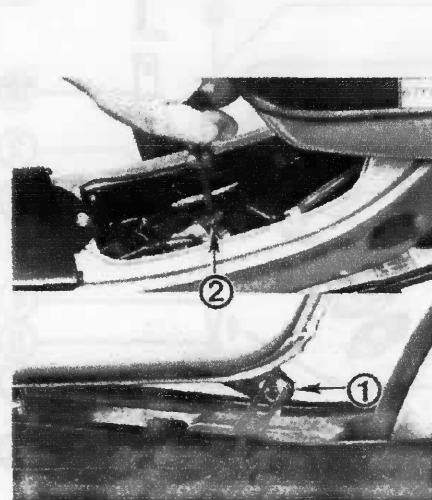
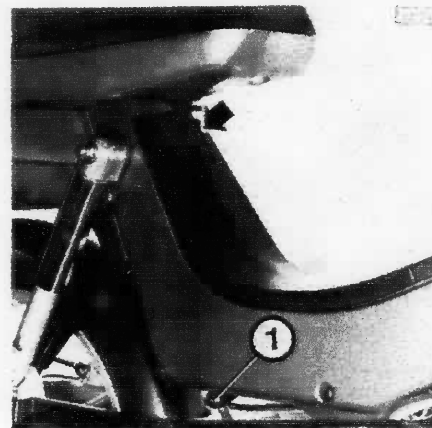
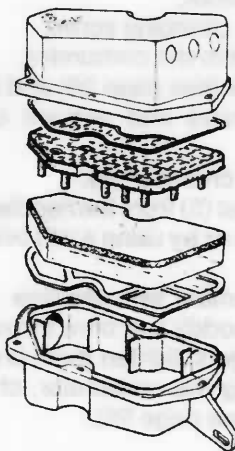

LUBRICATION AND MAINTENANCE

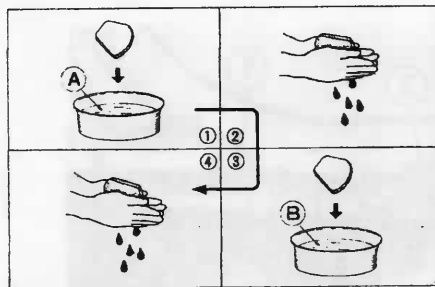

(A) Non flammable cleaning solvent

(B) Engine oil

Cleaning the element.

Fill a washing pan with non-flammable cleaning solvent. Immerse the element in the cleaning solvent (A) and wash it clean (see below). Squeeze the solvent out of washed element by pressing it between the palms of both hands: **Do not twist or wring the element or it will develop tears.** Immerse the element in engine oil (B) and squeeze the oil out of the element leaving it slightly wet with oil.

CAUTION:

Before and during the cleaning operation, inspect the element for tears. A torn element must be replaced. Be sure to position the element snugly and correctly, so that no incoming air will bypass it. Remember, rapid wear of piston rings and cylinder bore is often caused by a defective or poorly fitted element.

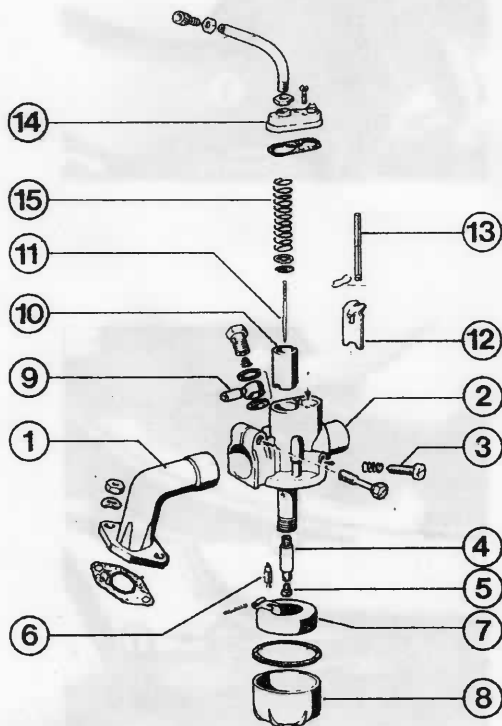

Cleaning the carburetor (old type)

Cleaning the main jet, needle jet and float chamber

- 1) Close the fuel valve.
- 2) Remove the left hand chain guard.
- 3) Remove the air cleaner.
- 4) Loosen carburetor clamping screw.
- 5) Pull the fuel pipe from the carburetor.
- 6) Turn the carburetor (see page 28) and pull off.
- 7) Loosen cover screws and remove cover (14) with throttle slide.
- 8) Screw off the float chamber (8).
- 9) Unscrew the main jet (5) from the needle jet (4) and clean by blowing through or by using a stiff bristle. Never use a piece of wire.
- 10) Clean the float chamber with gasoline
- 11) Wash carburetor body and blow through.
- 12) When refitting the jets, tighten them properly
- 13) Before reassembling the carburetor, check for correct float adjustment (see page 56).

LUBRICATION AND MAINTENANCE

Cleaning the carburetor (new type)

- 1) Close the fuel valve
- 2) Remove the center frame cover.
- 3) Remove air cleaner (see page 27).
- 4) Loosen carburetor clamp screw (1) and remove from manifold.
- 5) Remove fuel hose from carburetor.
- 6) Loosen cover screws (2) and remove cover with throttle slide (3) and choke slide (6).
- 7) Unscrew float chamber (10) and clean.
- 8) Unscrew main jet (7) from needle jet (8) and clean by blowing through or using a stiff bristle. Never use a piece of wire.
- 9) Remove fuel strainer (4) and blow through.
- 10) Wash carburetor body and blow through.
- 11) When refitting the jets, tighten them properly.
- 12) Before reassembling the carburetor, check for correct float adjustment (see page 56).

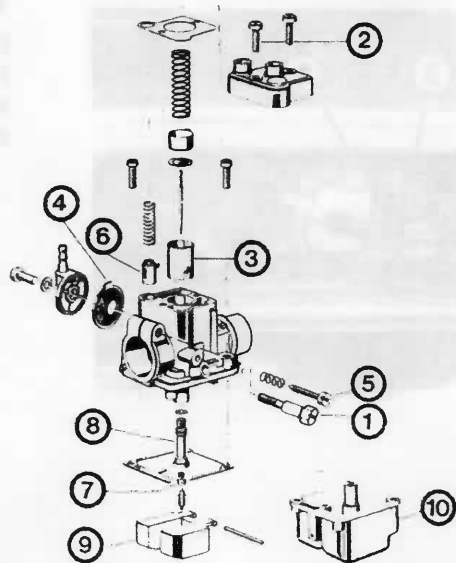

CARBURETOR ADJUSTMENT

Minor carburetor adjustment may be required to compensate for differences in fuel, temperature, altitude and load.

IDLE ADJUSTMENT

Start engine and run at moderate speed until operating temperature is reached. Adjust idle speed by turning idle adjustment screw (3).

AUSTRO DAIMLER

Turn adjustment screw (5, see above drawing) in or out until engine runs smoothly.

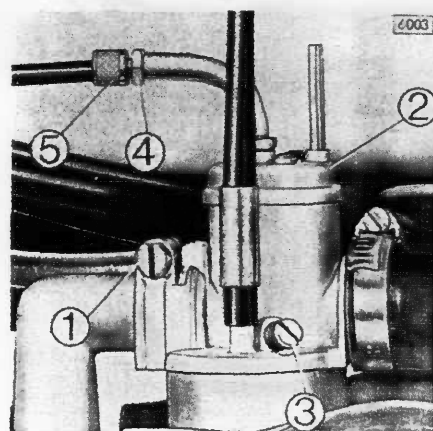

LUBRICATION AND MAINTENANCE

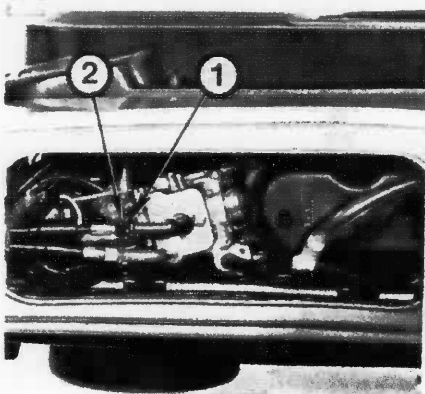

THROTTLE CABLE ADJUSTMENT

Check for proper throttle cable slack (.040 in./1.0 mm). Insufficient cable slack will hold the throttle partially open and the idle adjusting screw will not function. If necessary, loosen the cable locknut.

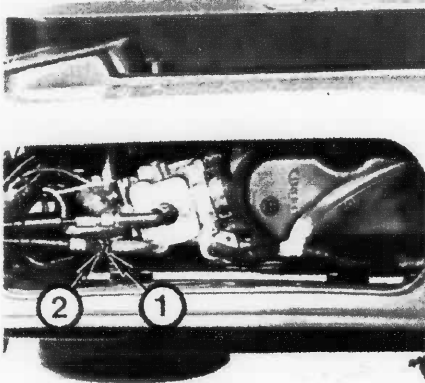

CHOKE CABLE ADJUSTMENT - AUSTRO DAIMLER

Check for proper choke cable slack (.080 in./2.0 mm). Insufficient cable slack will hold choke slide in partially open position and engine will run too rich. Loosen adjuster lock nut and turn adjuster in or out to obtain correct cable slack.

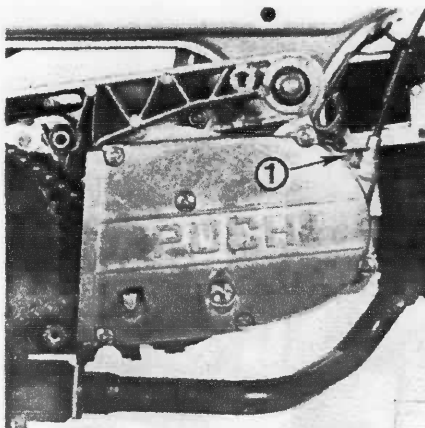

ADJUSTMENT OF STARTER CLUTCH CABLE

The starter lever should have a play of app. 1/2 inch as measured outside at the lever end. The adjustment is made with the adjustment screw (1). The rubber cap must be slid back first.

LUBRICATION AND MAINTENANCE

Checking the brakes

Front brake

The correct free travel (measured at the end of the hand-brake lever) is $\frac{3}{4}$ in. (2 cm). To adjust, loosen the locknut (1) and turn the adjuster until brake lever travel is $\frac{3}{4}$ in. (2 cm). Tighten the locknut.

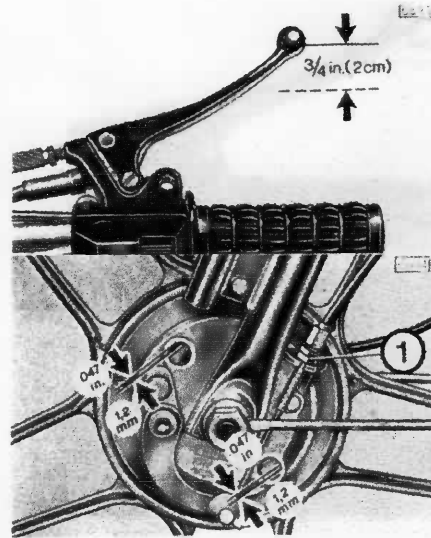

CHEKING THE IGNITION SYSTEM

Ignition timing

The engine will reach maximum output only if the ignition is correctly adjusted. See Ignition Timing page 111.

Adjusting the starting lever

After the first 300 miles (480 km) and then every 3600 miles (5800 km) check adjustment of the starting lever. The free play at the starting lever (measured at the end of the lever) should be $\frac{3}{4}$ in. (2 cm). Correct play is achieved by loosening the locknut (1) and turning the adjuster until the correct lever travel is obtained. Tighten the locknut.

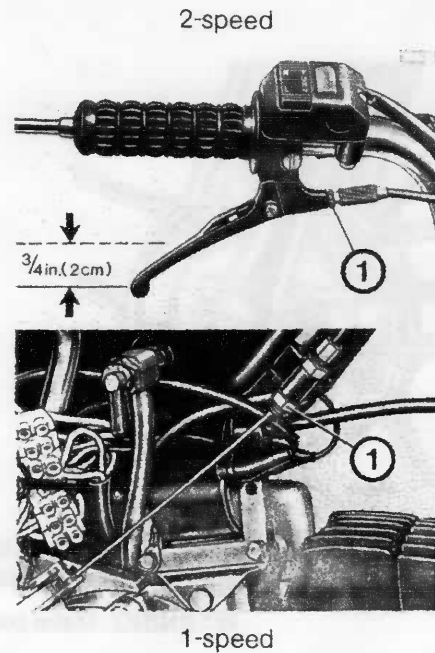

LUBRICATION AND MAINTENANCE

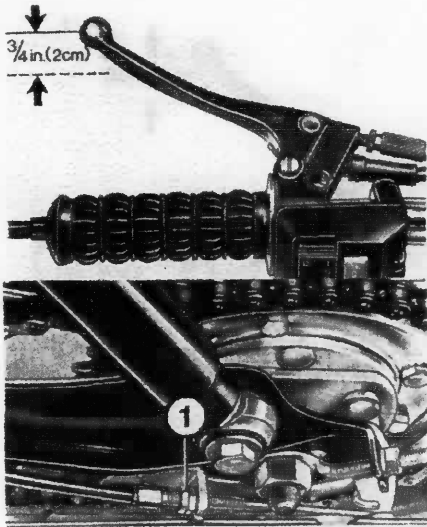

Rear Brake

The correct free travel (measured at the end of the hand-brake lever) is $\frac{3}{4}$ in. (2 cm). To adjust, loosen the locknut (1) and turn the adjuster until brake lever travel is $\frac{3}{4}$ in. (2 cm). Tighten the locknut.

Brake linings

Pry plastic inspection plugs from wheel hub. Disconnect brake cable from brake lever. Insert a feeler gauge between brake drum and brake lining. Gap should not exceed .047 in. (1.2 mm) at either inspection hole. If gap exceeds this measurement, refer to section "BRAKES" on brake replacement.

FRONT WHEEL REMOVAL

Unscrew speedometer cable from hub. Loosen locknut on brake cable and remove brake cable from hub. Remove the axle nuts. Remove wheel from fork.

To replace wheel, reverse the above procedure. Torque axle nuts to 20 ft/lb (27 Nm). Be certain to readjust the brake before riding.

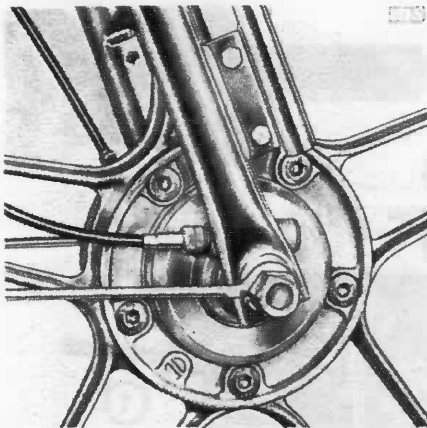

 When reinstalling the wheel, make sure that the brake anchor plate engages into the pinion of the front fork.

WARNING: Make sure that axle is tightened.

LUBRICATION AND MAINTENANCE

REAR WHEEL REMOVAL – AUSTRO DAIMLER

Dismount both covers. Remove the r.h. axle nut (1), loosen chain tensioners (2) and (8). Disconnect rear brake cable (4). Remove brake anchor screw (6) and chain master link. Loosen cover retaining screws (9) and (10) and tilt cover down. Remove axle (7).

WARNING: When reinstalling the wheel, make sure the axle nut is tightened.

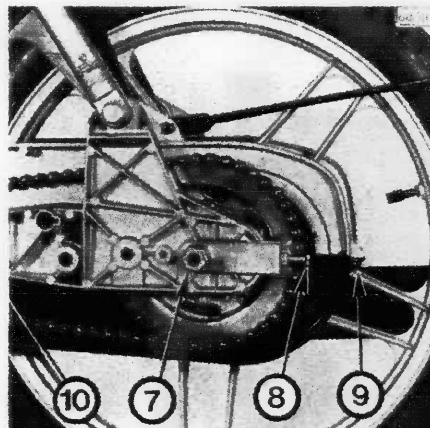
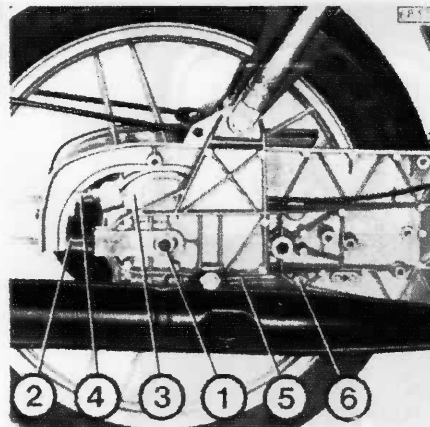

REPLACING HEADLIGHT BULB – MAXI-MAGNUM

Remove headlight rim retaining screw(s) and remove reflector. Turn bulb to the left and remove. Install original replacement bulb only (see your local Dealer).

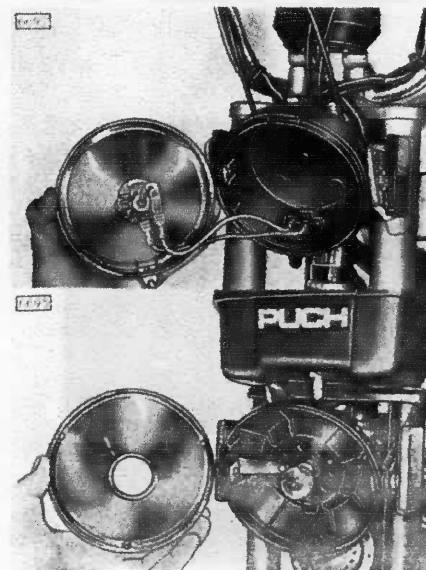

LUBRICATION AND MAINTENANCE

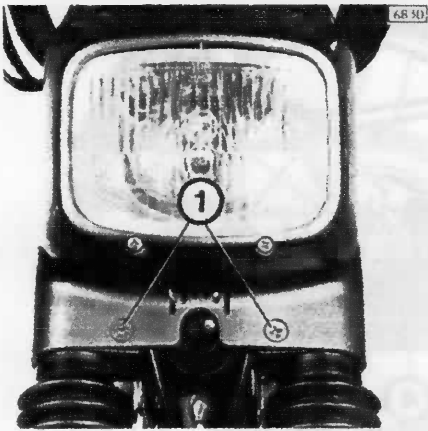

Replacing head light bulb – AUSTRO DAIMLER

Remove both retaining screws (1) and lift off head light assembly.

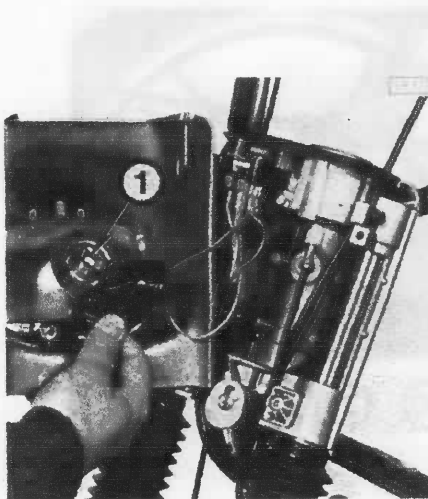

Fold back rubber cap, twist contact plate (1) aside and remove bulb.

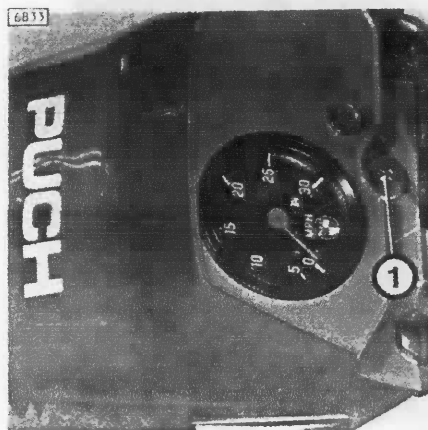

Replacing head light bulb – DART

Loosen screw (1).
Push headlight covering to the top and then pull it to the front.

LUBRICATION AND MAINTENANCE

Twist bulb socket in the direction of the arrow. Exchange bulb.

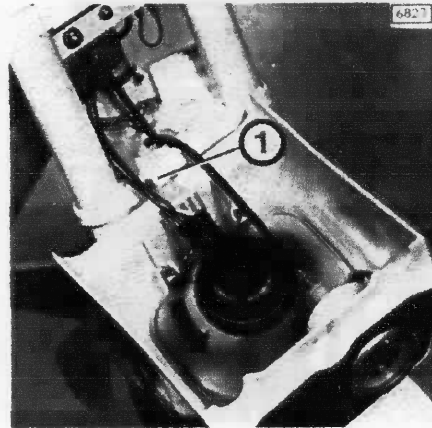

Checking the Headlight Adjustment

Load vehicle (with one person or 150 LBS) and place it on even ground at a 5 m distance from a vertical wall.

Measure at headlight glass:

Height of the center from the ground (H) in cm.

Place on the wall:

A centerline vertical to the longitudinal axis of the vehicle (C), and a horizontal line at the height "H".

If the light is adjusted correctly, the light-dark limit should be 5 cm below the horizontal line (H).

For higher or lower setting turn screws (1) in or out.

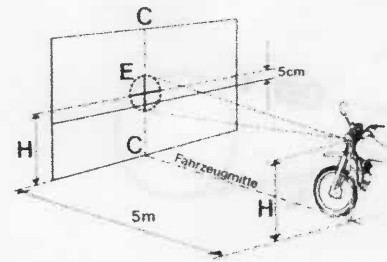

AUSTRO DAIMLER and DART Series

For higher and lower setting turn screws (1) in or out.

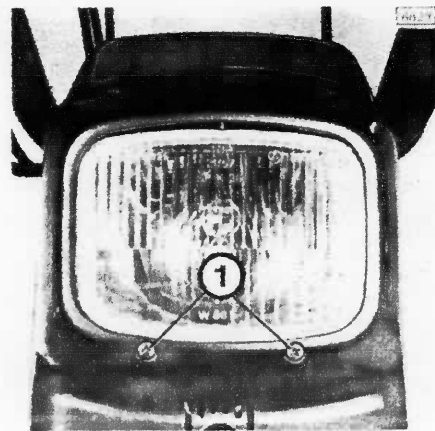

LUBRICATION AND MAINTENANCE

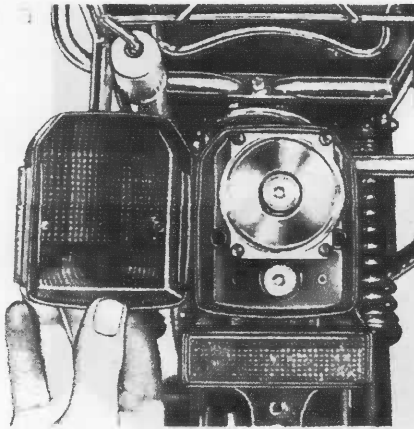

REPLACING REAR LIGHT BULB AND STOP LIGHT BULB

Remove the two screws that hold the lens. Remove bulb and replace. Stop light bulb (top) and rear light bulb (bottom).

Chains

Engine drive-and pedal chain should be kept clean. Every few hundred miles wipe chains thoroughly clean with a cloth. Lubricate with chain lubricant or SAE 90 oil.

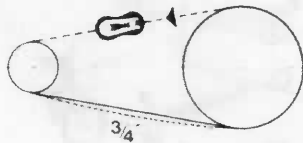

Always keep chains properly tensioned. The proper slack of the drive chain should be $\frac{3}{4}$ ".

To adjust chains, loosen the axle nuts and tighten or loosen the adjuster nuts. Once chains are properly adjusted, tighten the axle nuts. Make sure that wheel is properly aligned.

When reinstalling the chain also pay attention as to the correct position of the chain lock (closed part in riding direction) and to proper chain tension.

If pedal chain tensioner catches or travels roughly as pedals are operated, realign tensioner so chain travels smoothly.

EXPLODED ENGINE VIEW



1 SPEED AUTOMATIC ENGINE

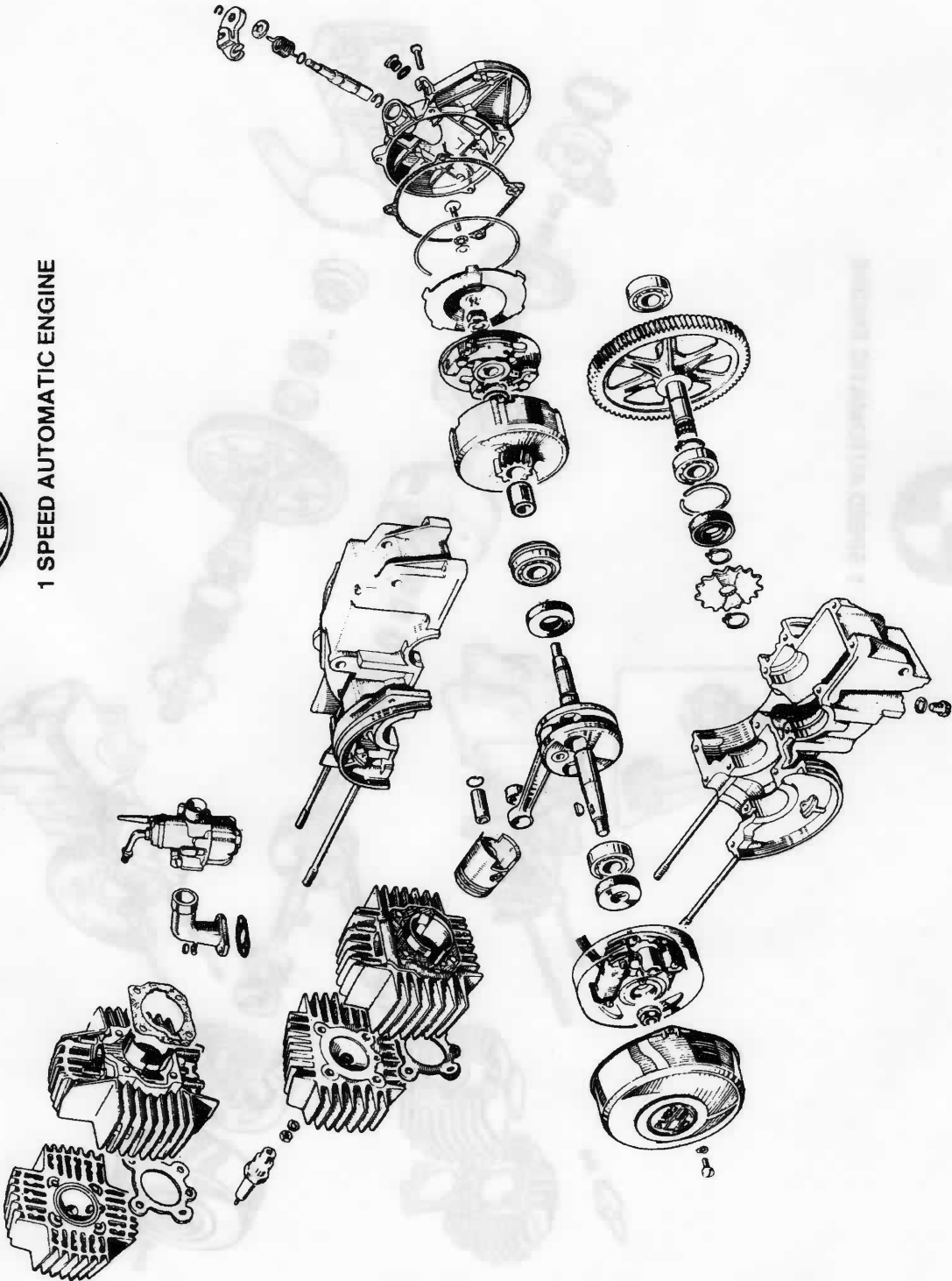

EXPLODED ENGINE VIEW



1 SPEED AUTOMATIC ENGINE

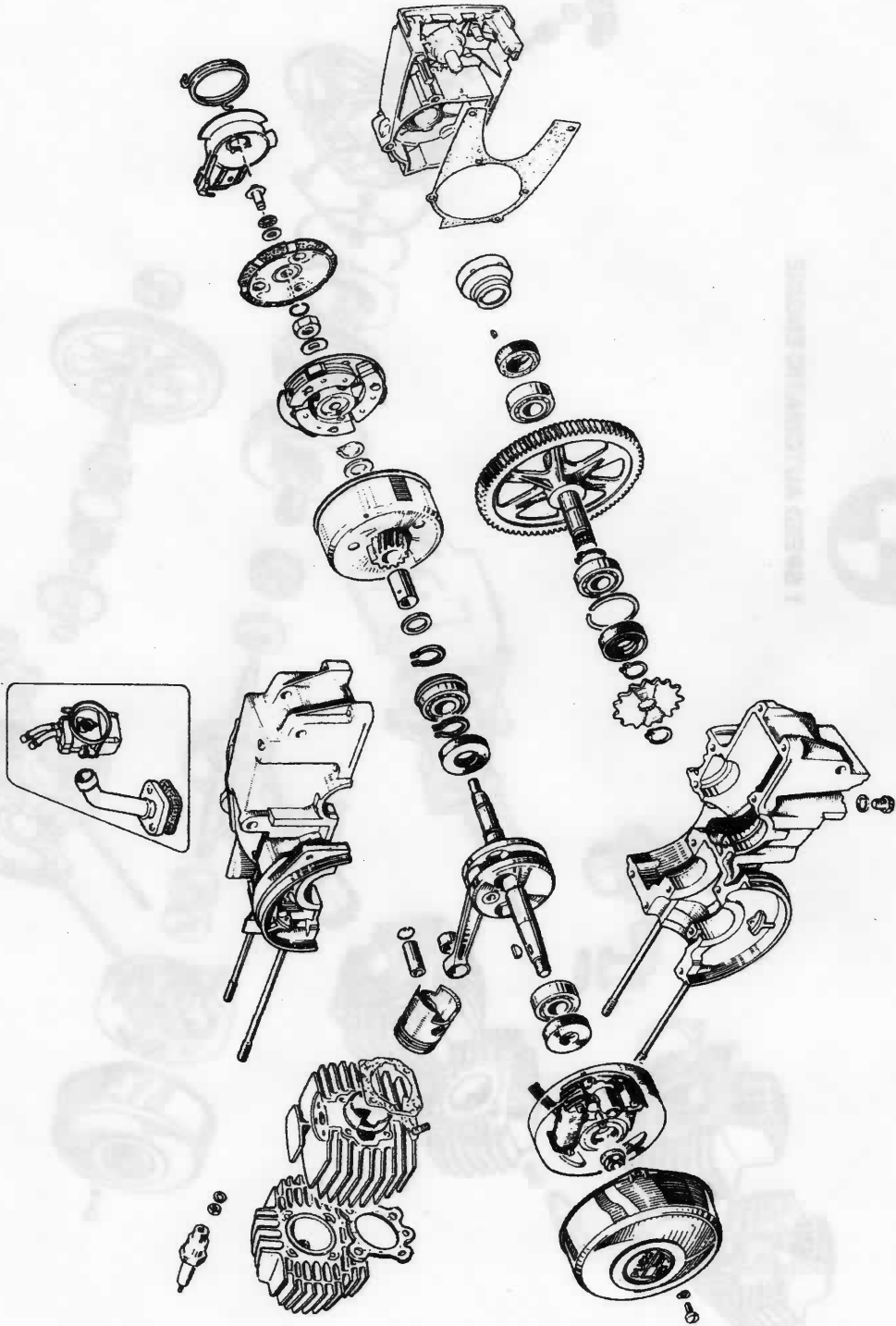

EXPLODED ENGINE VIEW



2 SPEED AUTOMATIC OIL INJECT

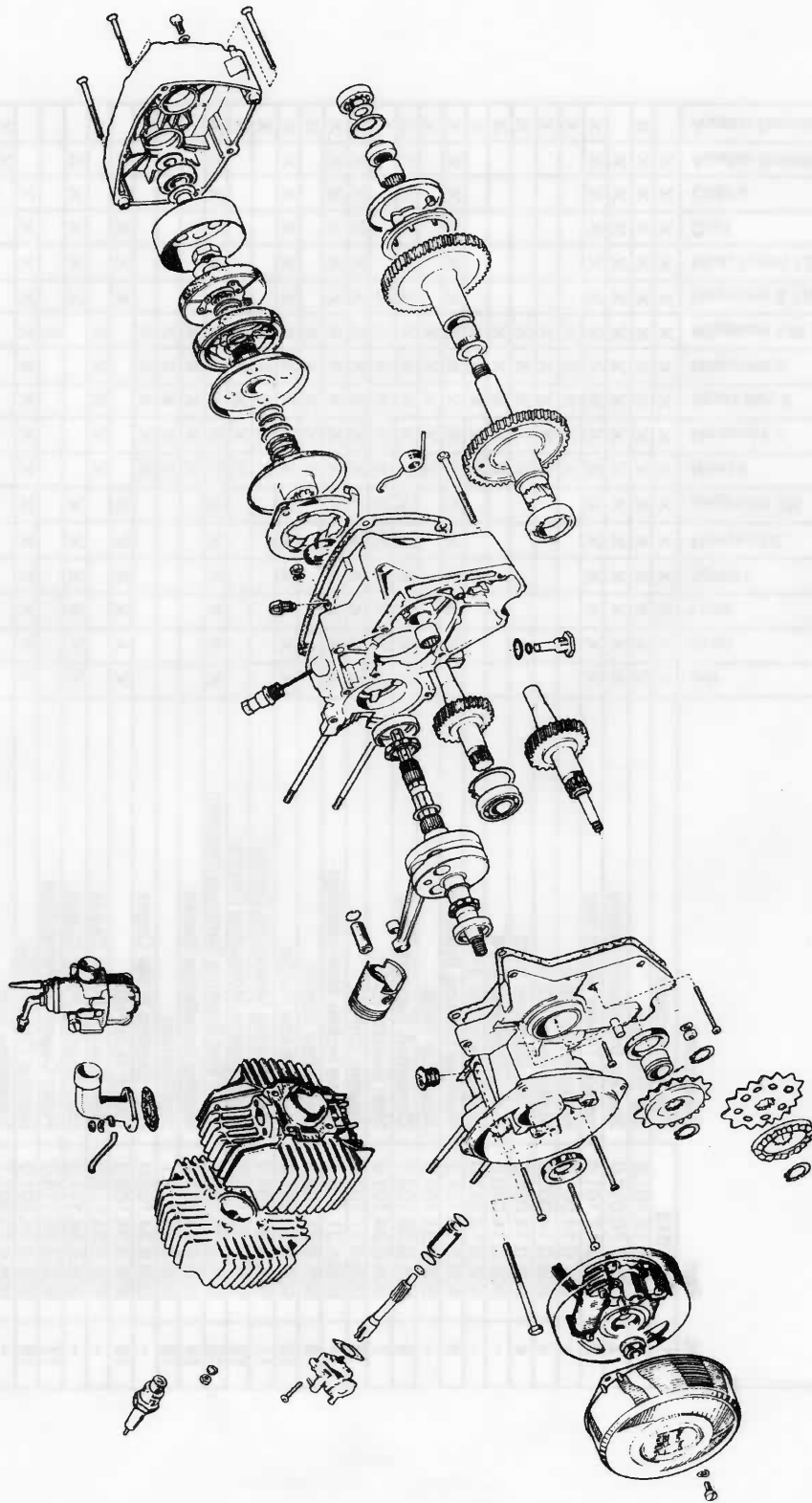

SPECIAL TOOLS

COMPLETE SPECIAL TOOL LISTING USAGE

Pic.	Part	Description	GN	Maxi	Luxe	Sport I	Newport/L	Magnum XK	Maxi II	Newport II	Sport MK II	Magnum II	Magnum MK II	Magnum X (JMX)	Maxi Sport LS	Dart	Cobra	Austro Daimler	Austro Daimler 2
1	050.7012	Flywheel Extractor	X	X	X	X	X	X	X	X	X	X	X	X	X	X	X	X	X
-	905.6.12.101.0	Dial Indicator	X	X	X	X	X	X	X	X	X	X	X	X	X	X	X	X	X
2	350.1.70.012.0	Bearing Installation Sleeve	X	X	X	X	X	X	X	X	X	X	X	X	X	X	X	X	X
3	905.0.12.101.0	Ignition Timing (Buzz) Box	X	X	X	X	X	X	X	X	X	X	X	X	X	X	X	X	X
-	905.0.14.001.0	Kukko-Puller 22-2																	
4	905.0.14.002.0	Kukko-Puller 22-1																	
4	905.0.14.006.0	Kukko-Remover 21/2																	
-	905.0.14.010.0	Kukko-Remover 21/6																	
-	905.0.14.017.0	Kukko-Remover 21/02																	
5	906.0.16.101.2	Flywheel Locking Spanner	X	X	X	X	X	X	X	X	X	X	X	X	X	X	X	X	X
-	905.0.31.101.2	Assembly Table																	
6	905.0.33.104.1	Crankshaft Support Table	X	X	X	X	X	X	X	X	X	X	X	X	X	X	X	X	X
7	905.0.34.101.0	Main Bearing Puller	X	X	X	X	X	X	X	X	X	X	X	X	X	X	X	X	X
8	905.6.17.101.0	Reamer compl.	X	X	X	X	X	X	X	X	X	X	X	X	X	X	X	X	X
-	905.6.31.106.2	Engine Holder (non-rotating)	X	X	X	X	X	X	X	X	X	X	X	X	X	X	X	X	X
9	905.6.31.108.1	Installation Sleeve	X	X	X	X	X	X	X	X	X	X	X	X	X	X	X	X	X
10	905.6.32.101.0	Dial Indicator Holder	X	X	X	X	X	X	X	X	X	X	X	X	X	X	X	X	X
11	905.6.32.107.0	Main Bearing Measuring Device																	
12	905.6.32.109.0	Transmission Measuring Device																	
13	905.6.33.105.0	Small End Bushing Remover/Installer	X	X	X	X	X	X	X	X	X	X	X	X	X	X	X	X	X
14	905.6.33.111.2	Bearing Installation Sleeve																	
15	905.6.33.112.1	Seal Installer																	
-	905.6.34.105.0	Main Bearing Puller Cages																	
16	905.6.34.109.0	Clutch Hub Puller	X	X	X	X	X	X	X	X	X	X	X	X	X	X	X	X	X
-	905.6.34.110.0	Main Bearing Puller Cages																	
-	905.6.34.111.0	Main Bearing Puller Cages	X	X	X	X	X	X	X	X	X	X	X	X	X	X	X	X	X
17	905.6.34.113.0	Puller Cages Oil Pump Gear	X	X	X	X	X	X	X	X	X	X	X	X	X	X	X	X	X
18	905.6.34.501.0	Bearing Cup Installer	X	X	X	X	X	X	X	X	X	X	X	X	X	X	X	X	X
-	905.6.33.301.1	Installation tool																	
19	905.6.35.401.2	Spoke Spanner	X	X	X	X	X	X	X	X	X	X	X	X	X	X	X	X	X
20	905.6.35.402.1	Hub Cone Spanner	X	X	X	X	X	X	X	X	X	X	X	X	X	X	X	X	X
21	905.6.35.404.0	Sprocket Spanner	X	X	X	X	X	X	X	X	X	X	X	X	X	X	X	X	X
22	905.6.36.108.0	Engine Holder (rotating type)	X	X	X	X	X	X	X	X	X	X	X	X	X	X	X	X	X
23	905.6.36.109.2	Second Gear Locking Device																	
23	905.6.36.110.2	Clutch Locking Device																	
24	905.6.41.101.2	Spring Pliers																	
-	905.6.28.601.0	PUCH Low Scale Ohmmeter	X	X	X	X	X	X	X	X	X	X	X	X	X	X	X	X	X
-	905.6.28.602.0	PUCH Ignition Tester	X	X	X	X	X	X	X	X	X	X	X	X	X	X	X	X	X
-	905.1.15.102.0	Steering head wrench	X	X	X	X	X	X	X	X	X	X	X	X	X	X	X	X	X

SPECIAL TOOLS

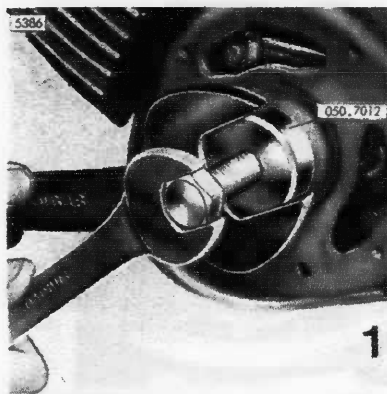

1

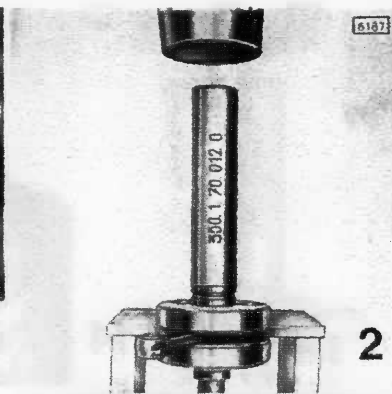

2

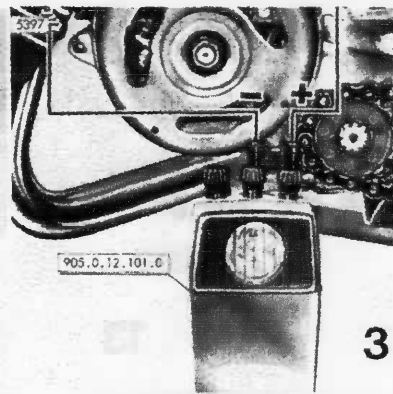

3

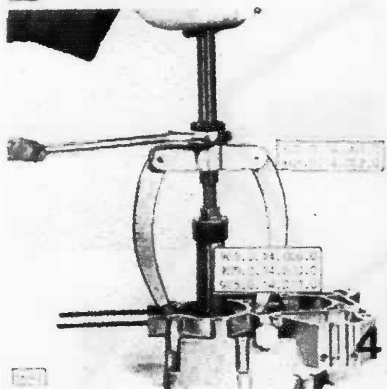

4

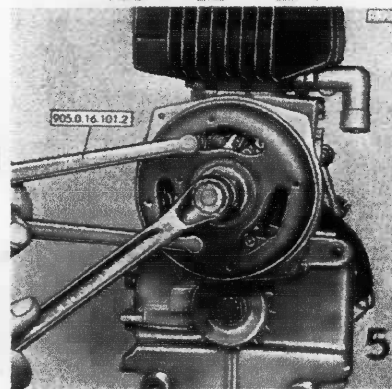

5

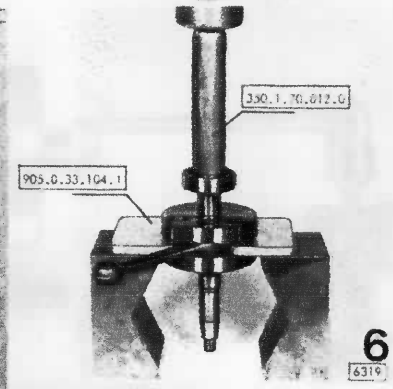

6

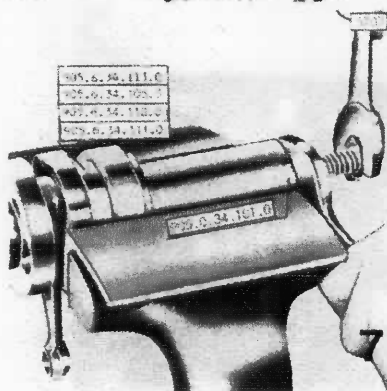

7

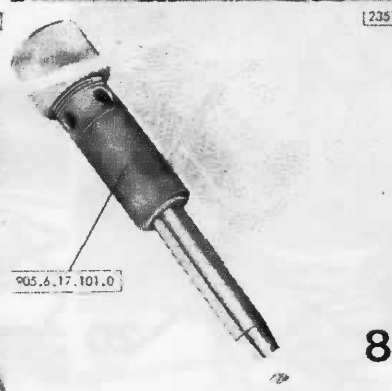

8

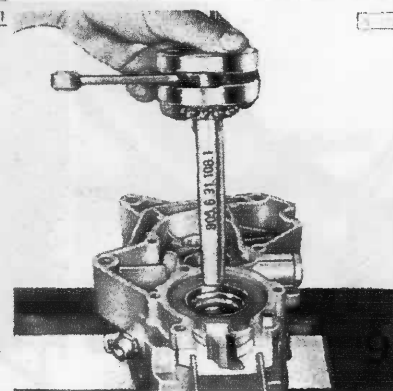

9

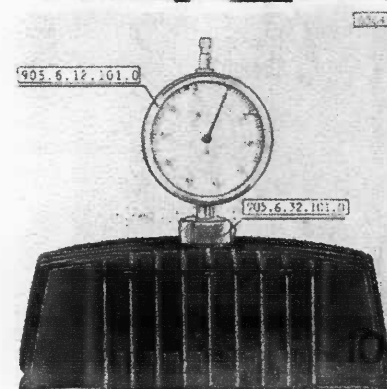

10

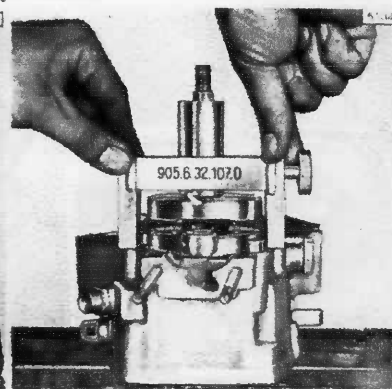

11

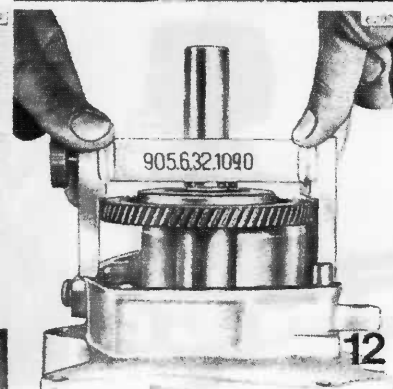

12

SPECIAL TOOLS

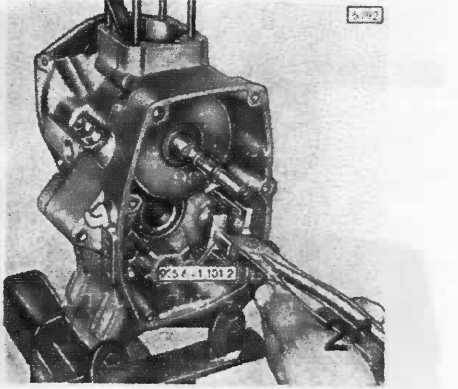
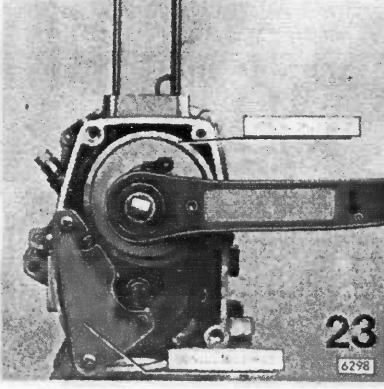
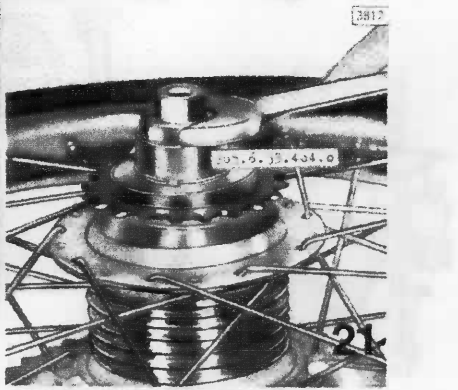
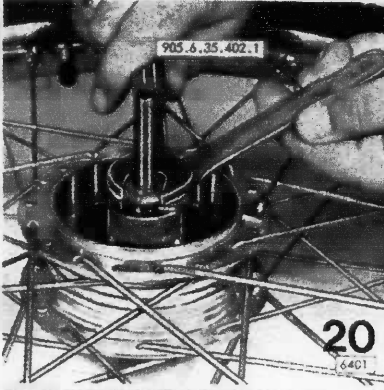
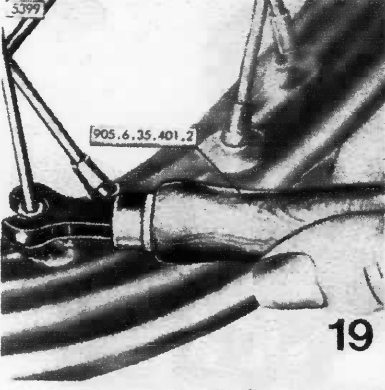
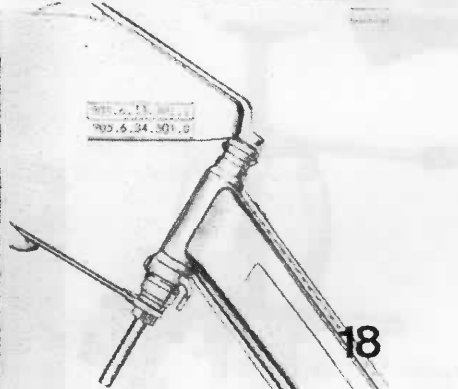
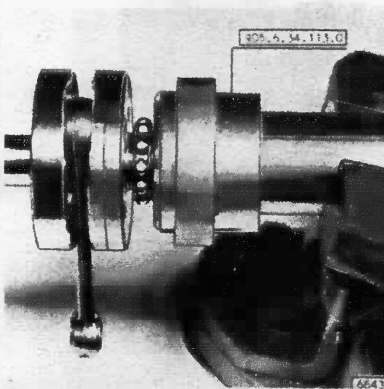
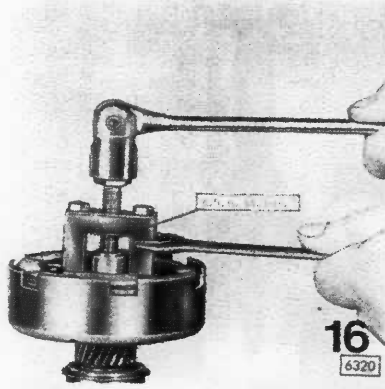
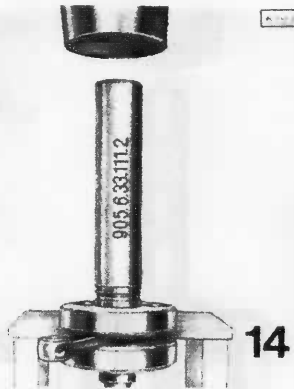
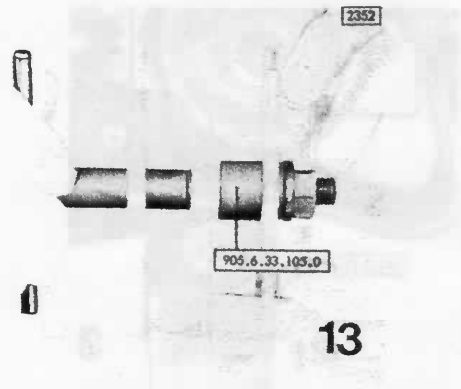

TORQUE SPECIFICATION

The torque reading in foot pounds is the torque required to bring any given bolt to its maximum safe stress point.

Tension is the pressure in pounds per square inch (P.S.I.) that the bolt material can stand before stretching occurs.

Tightening torque to be within a tolerance of 10%.

Engine torque specification

Spark plug	14 ft/lb (20 Nm)
Cylinder head nuts	7 ft/lb (10 Nm)
Flywheel nut	25 ft/lb (35 Nm)
Crankcase screws	6 ft/lb (8 Nm)
Clutch cover screws	6 ft/lb (8 Nm)
Engine mounting bolts	23 ft/lb (32 Nm)
Engine mounting bolts (A-D Series)	29 ft/lb (40 Nm)
Clutch retaining nut, 2 speed	22-29 ft/lb (30-40 Nm)
Roller retaining, l.h. thread, 2 speed	25-36 ft/lb (35-50 Nm)
Clutch retaining nut, 1 speed, old and new type	20 ft/lb (27 Nm)
Kickstand bearing bolts	6 ft/lb (8 Nm)
Manifold mounting bolts/nuts	6 ft/lb (8 Nm)

Frame torque specification

Front/rear axle nuts	20 ft/lb (27 Nm)
Front/rear axle nuts (A-D series)	20-22 ft/lb (25-30 Nm) 22-30 ft/lb (30-40 Nm)
Rear shock top	17 ft/lb (23 Nm)
Rear shock bottom	9 ft/lb (12 Nm)
Rear shock top (A-D series)	22-30 ft/lb (30-40 Nm)
Rear shock bottom (A-D series)	22-30 ft/lb (30-40 Nm)
Rear fork bearing	29 ft/lb (40 Nm)
Swing arm pivot bolt front (A-D series)	26-36 ft/lb (35-50 Nm)
Swing arm bolts (A-D series)	16-27 ft/lb (21-30 Nm)
Handlebar bolts	10-12 ft/lb (15-16 Nm)
Crank wedge nuts	5 ft/lb (7 Nm)
Fender bracket hardware	4 ft/lb (6 Nm)
Steering head nut	30 ft/lb (41 Nm)
Steering head nut top (A-D series)	18-36 ft/lb (25-50 Nm)
Fork tube clamp bolts (MAGNUM MK II)	40 ft/lb (54 Nm)
Fork tube clamp bolts (A-D series)	11-22 ft/lb (15-30 Nm)
Fork bridge plug screws (MAGNUM MK II)	20 ft/lb (27 Nm)
Fork bridge bolts, top	11 ft/lb (15 Nm)
Handlebar cover (A-D series)	11-16 ft/lb (16-22 Nm)
Hub screws-Mag. wheel	16-27 ft/lb (21-30 Nm)

NOTE: Nm stands for Newton-meter which is an European standard measure. Its conversion factor to receive ft/lb (foot-pounds) is 0,735.

REMOVE ENGINE

ENGINE REMOVAL

Place the moped on a bench. Secure in position on bench with tie-down straps.



Drain transmission oil.

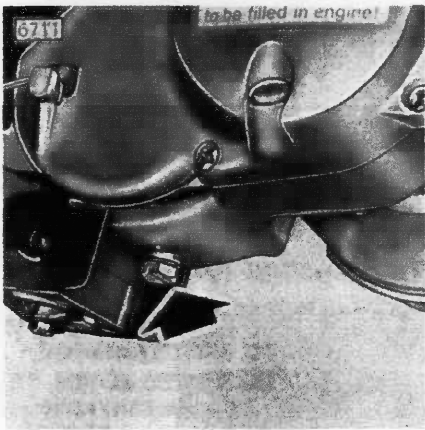

1-Speed

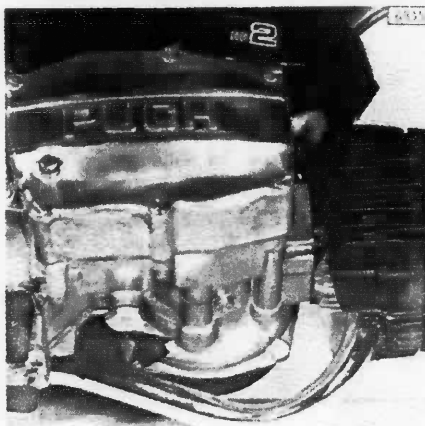

2-Speed

REMOVE ENGINE

Remove left and right hand chain guards.

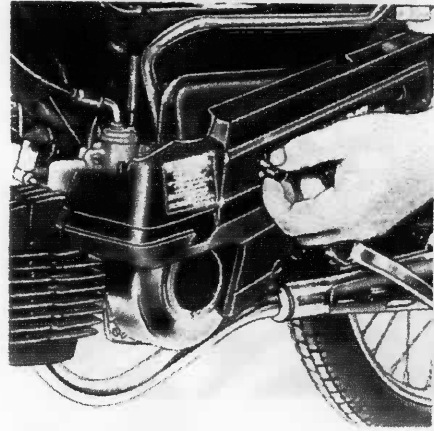

Loosen clamp screw on air filter assembly and remove.

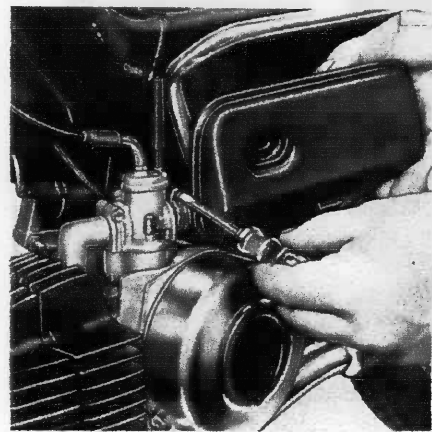

AUSTRO DAIMLER Series:

Loosen filter clamp screw (2), mounting bolt (1), twist filter to right and remove filter assembly.

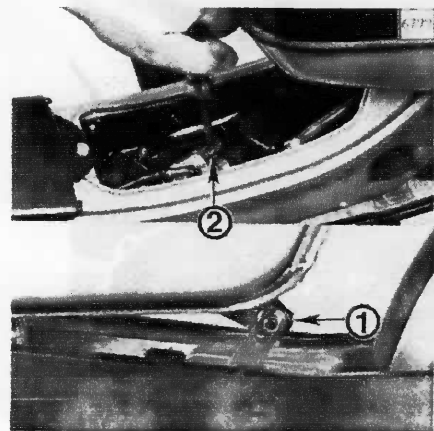

REMOVE ENGINE

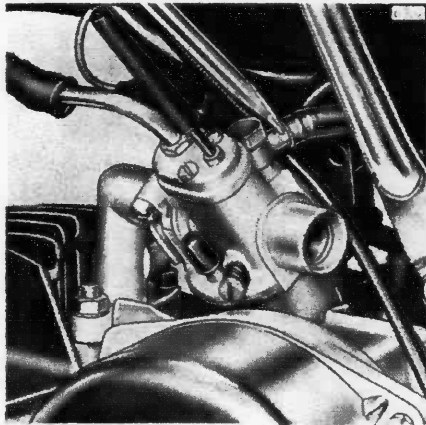

Turn fuel tap to "Off" position. Disconnect fuel supply hose. Loosen carburetor clamp screw and twist carburetor to the left and remove from intake manifold.

Remove both exhaust nuts on cylinder and the mounting bolt on the muffler housing. Remove exhaust system.

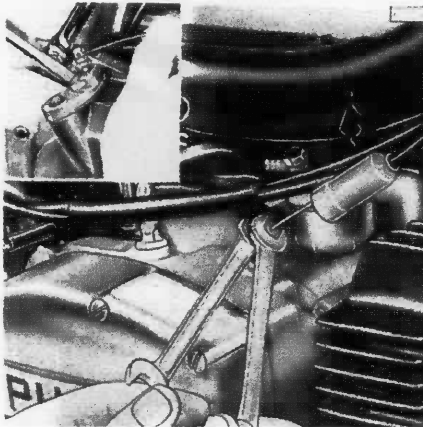

DISCONNECT STARTER CABLE:

1-speed automatic

Loosen starter cable adjustment, twist clutch lever and disconnect cable from lever.

2-speed automatic

Loosen clamp screw on starter lever. Pull up protective plastic cap from the adjusting sleeve. Unscrew starter cable nut from adjusting sleeve. Do not loosen adjusting sleeve nor the starter cable adjusting nut.

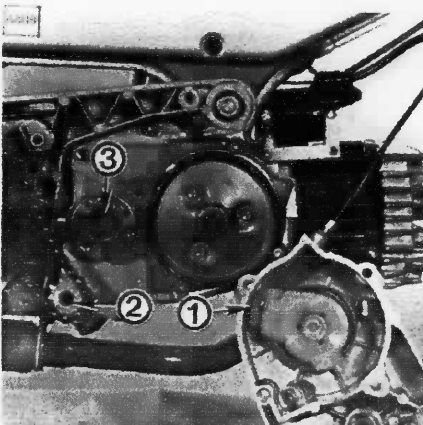

1-speed automatic, AUSTRO DAIMLER

Loosen clamp screw on starter lever, remove clutch cover and unhook cable at riser bearing (1). Remove pedal chain and sprocket (2) from drive shaft (3).

Remove the 3 engine retaining bolts (see page 98).

REMOVE ENGINE

2-speed automatic AUSTRO DAIMLER

Loosen clamp screw on starter lever.

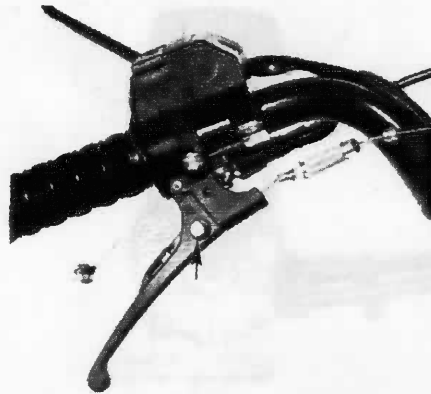

Pull up protective plastic cap from the adjusting sleeve and unhook inner cable from adjusting sleeve.

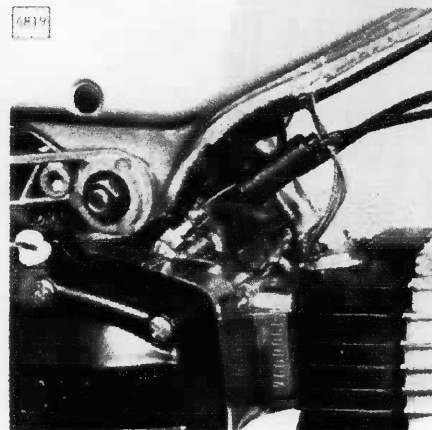

MAGNUM MK II:

Remove oil supply line from oil pump and block-off line to avoid oil drainage from oil tank.

Disconnect drive chain by removing the chain master link. Disconnect electrical wiring at junction block (generator side only).

Remove the three (3) engine mounting bolts and withdraw engine from frame.

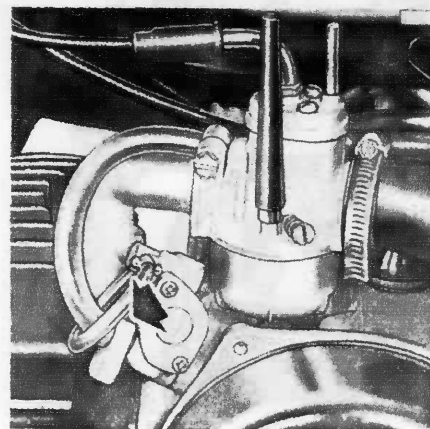

DISMANTLE ENGINE - 1 SPEED

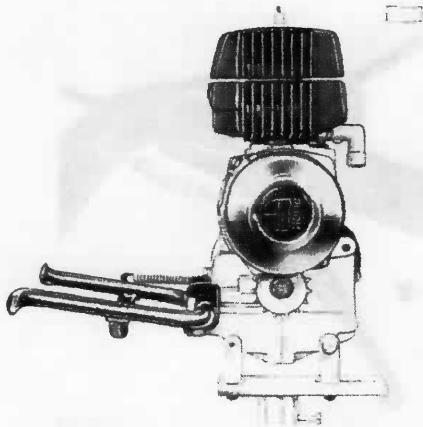

Place engine in engine holder (905.6.36.108.0) which is mounted in a vise.

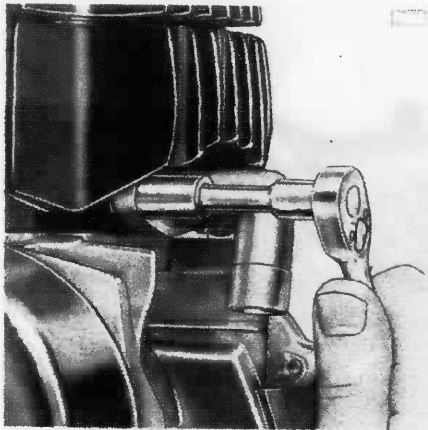

Remove intake manifold.

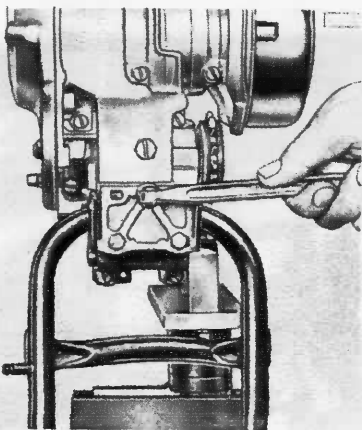

Disconnect the kick-stand spring. Unscrew the kickstand bearing bolts, bearing cup and kickstand.

DISMANTLE ENGINE - 1 SPEED

Remove generator cover

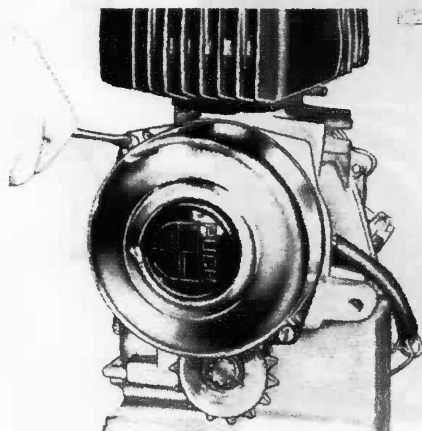

Lock flywheel with locking tool 905.0.16.101.2 and unscrew flywheel nut.

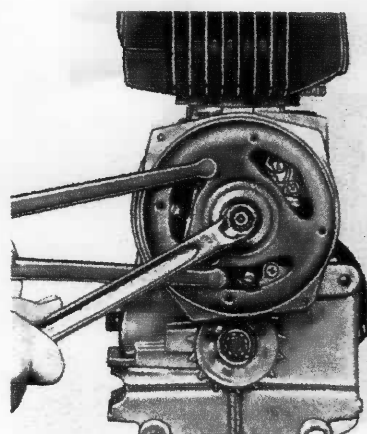

Break taper between flywheel and crankshaft with special puller 050.7012. Remove flywheel and woodruff key from crankshaft.

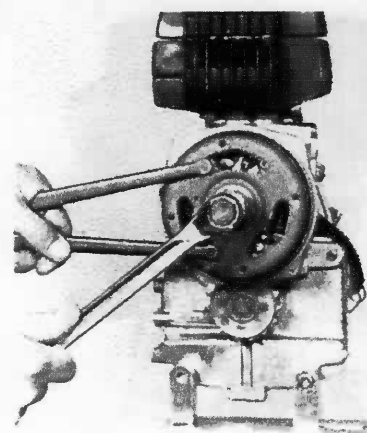

DISMANTLE ENGINE - 1 SPEED

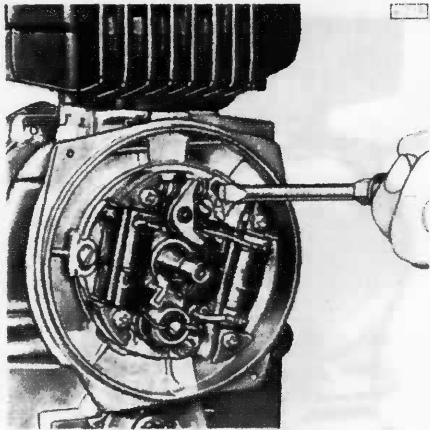

Unscrew the stator plate screws, remove the stator plate assembly and pull out the generator wiring including the rubber grommet.

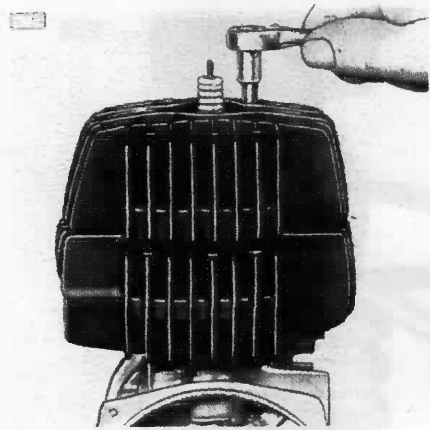

After removing the cylinder head nuts lift off the cylinder head and cylinder head gasket.

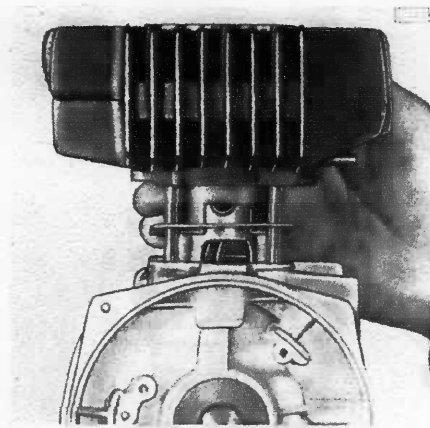

Remove cylinder and base gasket.

DISMANTLE ENGINE - 1 SPEED

Remove wrist pin retaining rings.

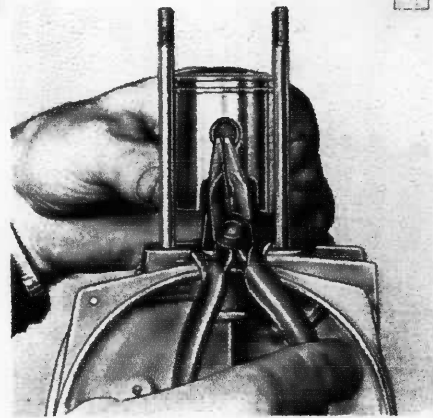

Push out the wrist pin and remove piston.

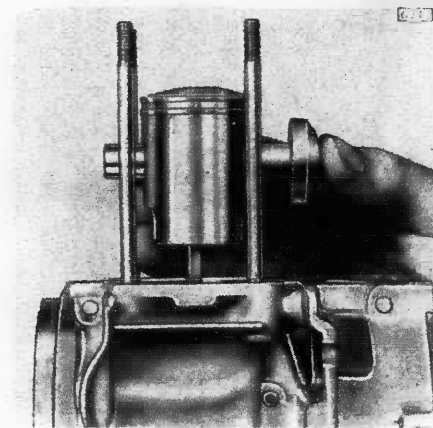

Remove clutch cover screws and clutch cover.

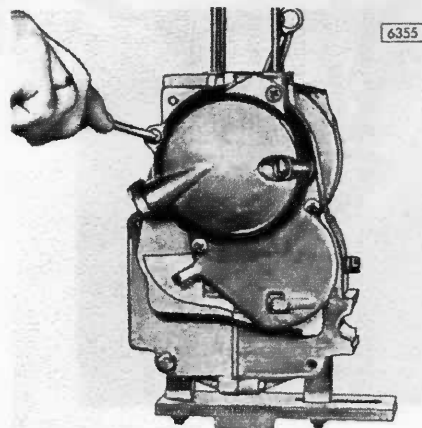

DISMANTLE ENGINE - 1 SPEED



Mount engine in engine stand so that the lower crankcase half is facing upward.

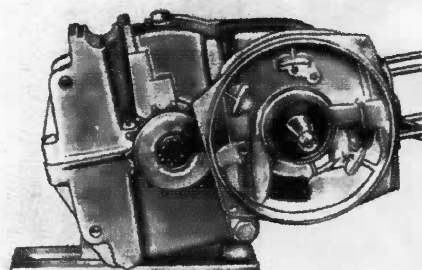

Remove all crankcase screws.

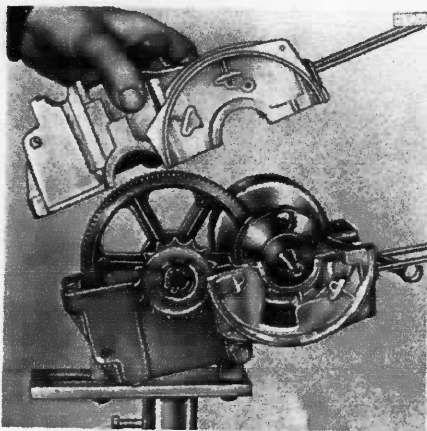
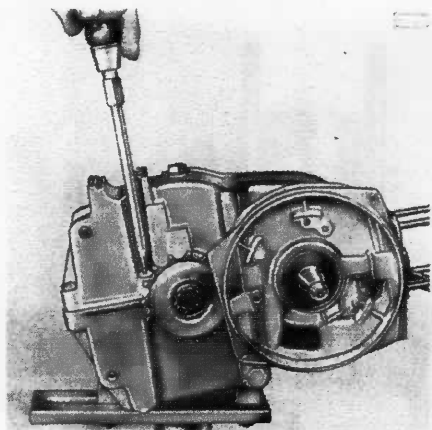

Slightly tap the upper crankcase half with a rubber hammer to break sealant between the two housing halves and remove top half.

DISMANTLE ENGINE - 1 SPEED

Lift primary drive assembly from lower crankcase half.

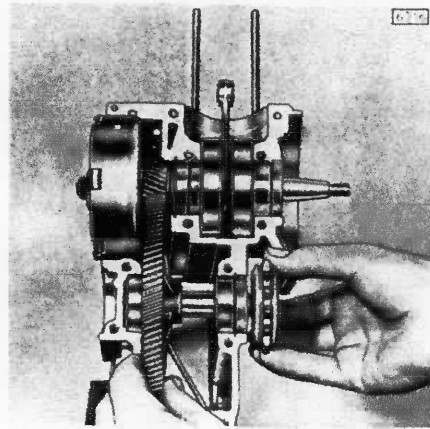

Remove crankshaft with clutch assembly.

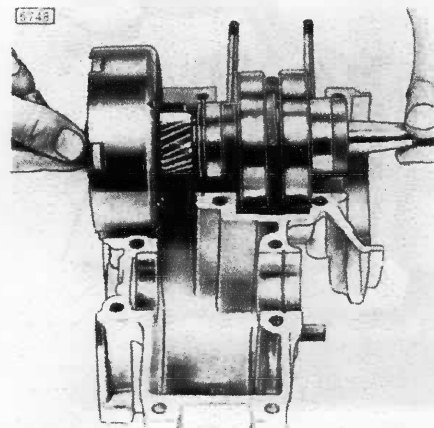

DISMANTLE CRANKSHAFT

Remove large retaining ring from clutch drum and lift off pressure plate.

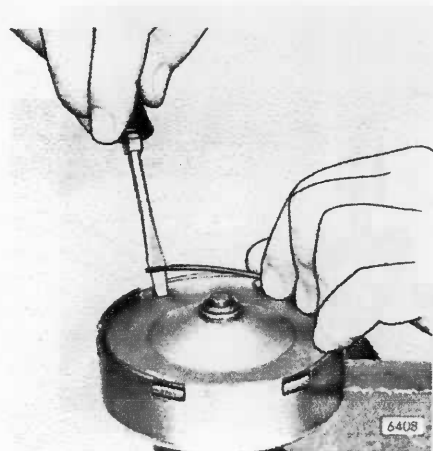

DISMANTLE ENGINE - 1 SPEED

Pressure plate AUSTRO DAIMLER and DART

Check pressure plate for wear or damage.

NOTE: Do not damage friction surface on clutch drum as this would rapidly wear friction material on pressure plate.

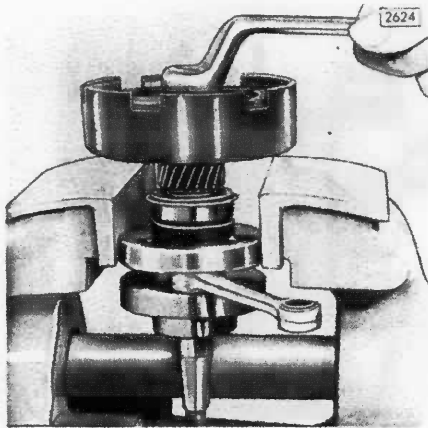
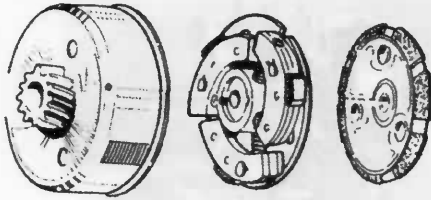

Place crankshaft between soft jaws in a vise, clamping the clutch side web only and remove clutch retainer nut.

! Ensure to clamp only the clutch side crank web, or damage to crankshaft is unavoidable.

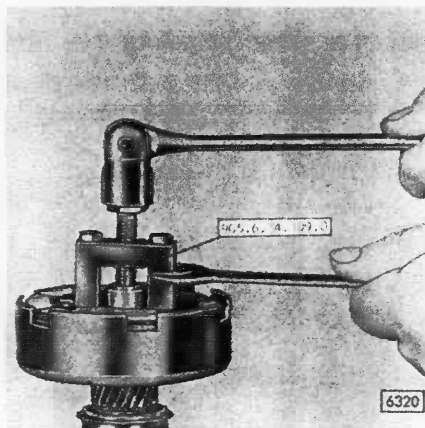

Use special puller 905.6.34.109.0 to remove centrifugal clutch from crankshaft. Remove clutch hub.

NOTE: Clutch assembly may also be dismantled with engine mounted in moped.

DISMANTLE ENGINE - 1 SPEED

Old type clutch assembly.

Remove circlip, shim, clutch drum and bushing.

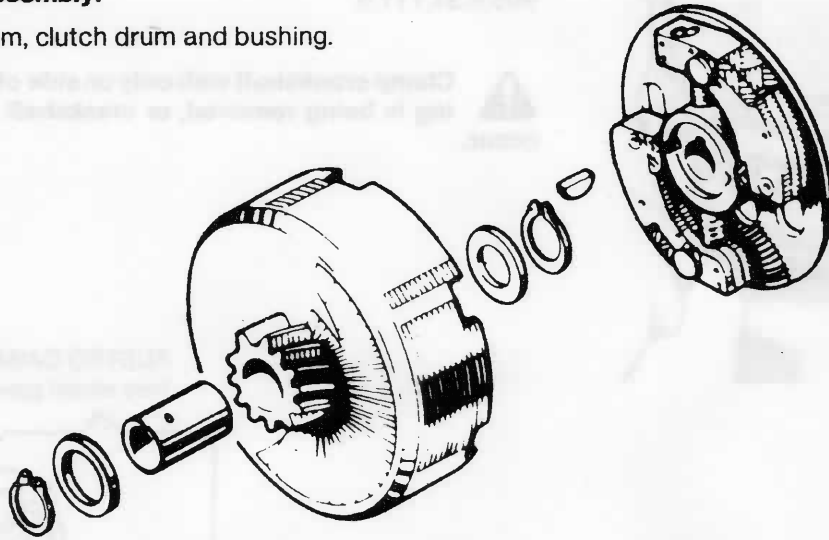

New type clutch assembly.

NOTE: The new type centrifugal clutch hub is interchangeable with the old type and the woodruff key is no longer required.

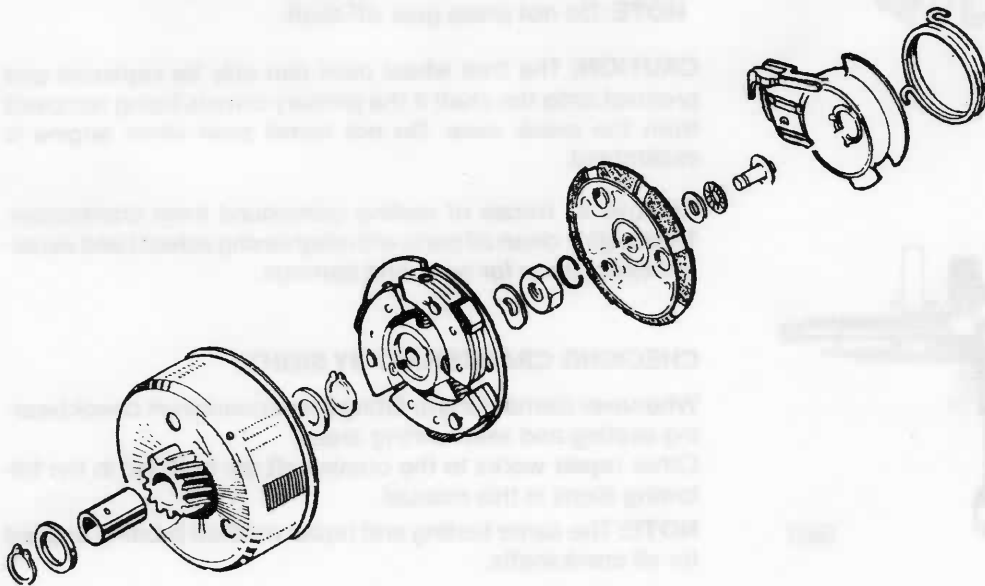

DISMANTLE ENGINE - 1 SPEED

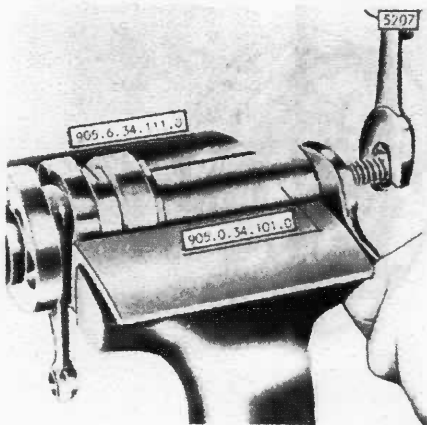

Remove main bearings with puller 905.0.34.101.0 and cages 905.6.34.111.0.



Clamp crankshaft web only on side of which bearing is being removed, or crankshaft damage will occur.

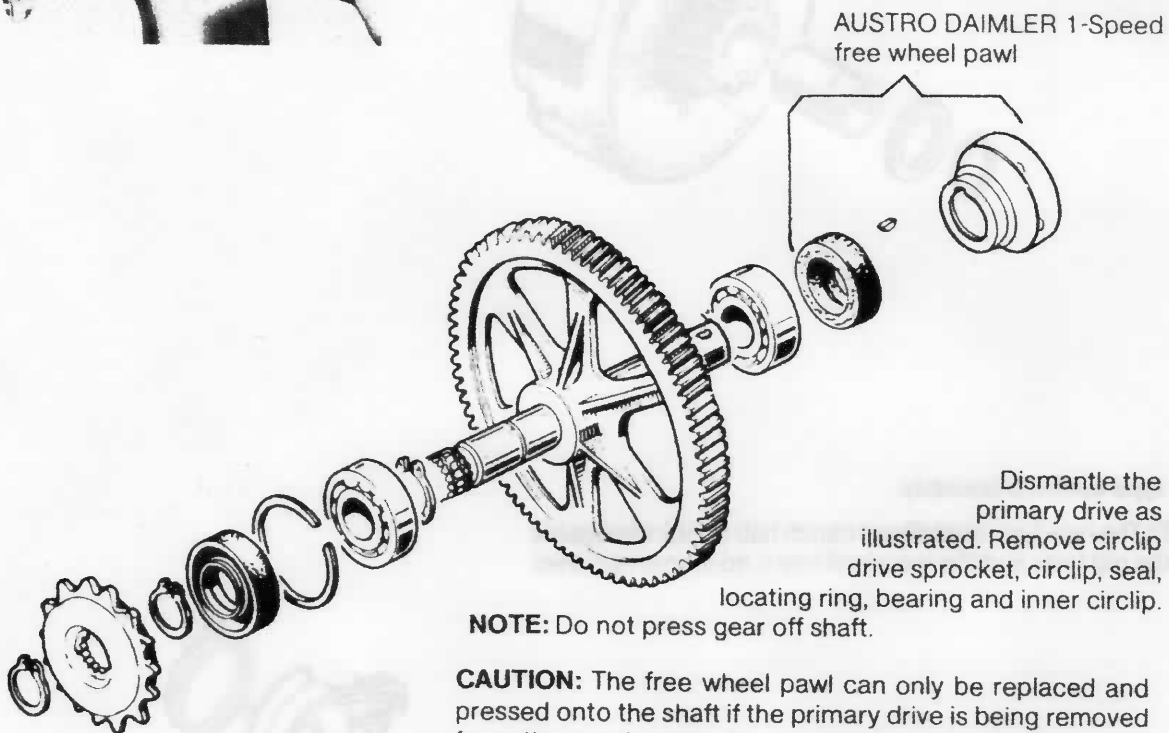

AUSTRO DAIMLER 1-Speed free wheel pawl

Dismantle the primary drive as illustrated. Remove circlip drive sprocket, circlip, seal, locating ring, bearing and inner circlip.

NOTE: Do not press gear off shaft.

CAUTION: The free wheel pawl can only be replaced and pressed onto the shaft if the primary drive is being removed from the crank case. Do not install pawl when engine is assembled.

Remove all traces of sealing compound from crankcase. Thoroughly clean all parts with degreasing solvent and visually inspect parts for wear and damage.

CHECKING CRANKSHAFT BY SIGHT

Whenever dismantling or fitting a new crankshaft check bearing seating and seal running areas.

Other repair works to the crankshaft are outlined in the following steps in this manual.

NOTE: The same testing and repair method is being applied for all crankshafts.

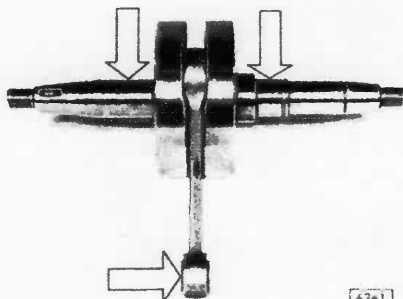

6361

CRANKSHAFT - WRIST PIN

BIG-END BEARING CLEARANCE

! If overheating, jamming or wear is apparent, crankshaft assembly must be replaced.

It is very difficult to measure the correct clearance and can only be carried out by the manufacturer. However, a very simple method is by firmly grasping the connecting rod to check for big end bearing wear. If rod is free but no play is noticeable, big end bearing is in good condition.

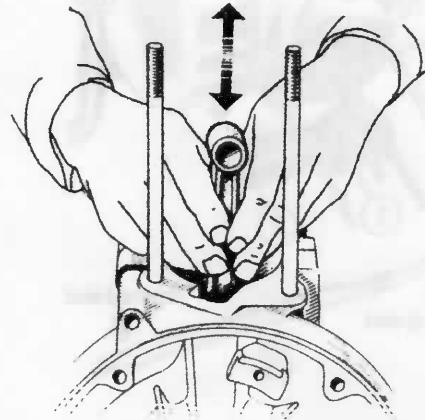

Before assembling an engine, always check the small end bushing for wear. If excessive wear is noticeable replace small end bushing.

SMALL END BUSHING:

Fitting limits	Wear limit
.473 - .474 in.	.475 in.
12,008 - 12,020 mm	12,025 mm

For correct wrist pin assortment and sizes see assorting table on page 40.

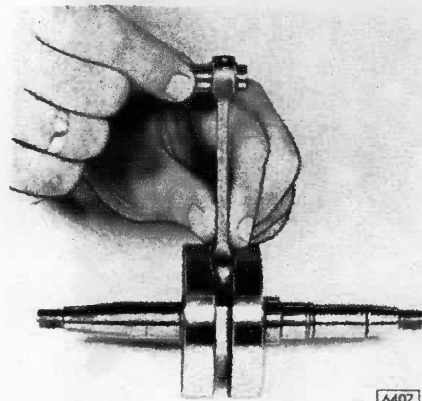

6407

REPLACING SMALL END BUSHING

Use special tool 905.6.33.105.0 to remove and replace bushing.

NOTE: Lubrication hole in bushing being installed and connecting rod small-end must be in line. If replacement bushing has no hole, one must be drilled after bushing is in position.

Wrist Pin	Wrist Pin	Wrist Pin	Wrist Pin
Wrist Pin	Wrist Pin	Wrist Pin	Wrist Pin
Wrist Pin	Wrist Pin	Wrist Pin	Wrist Pin
Wrist Pin	Wrist Pin	Wrist Pin	Wrist Pin
Wrist Pin	Wrist Pin	Wrist Pin	Wrist Pin

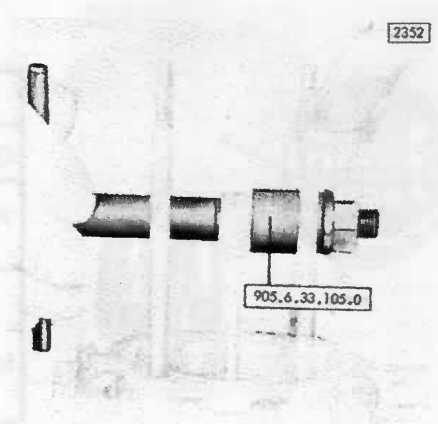

2352

905.6.33.105.0

CRANKSHAFT - WRIST PIN

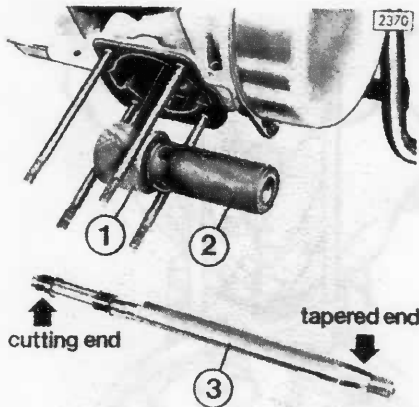

For centralizing and reaming use special tool 905.6.17.101.0. To enable accurate reaming place centralizing nut (1) over little end, insert guide sleeve (2) in centralizing nut. Insert tapered end of the reamer shaft (3) in guide sleeve and centralize tool over bushing. Tighten guide sleeve to centralizing nut.

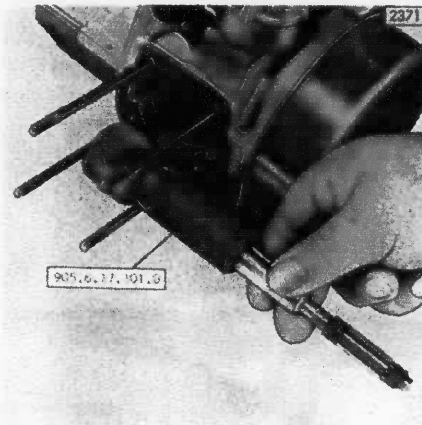

Adjust cutting edges of reamer to bushing size, remove from guide sleeve and tighten adjustment nuts on reamer. Applying oil to reamer, insert cutting end of reamer into guide sleeve, start reaming procedure until correct wrist pin bushing clearance is achieved.

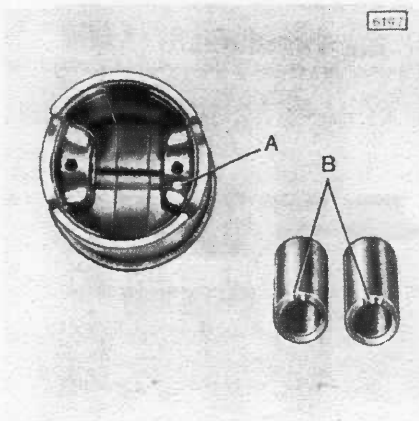

Wrist pin and piston fit is matched together and coded as follows:

Wear limit
yellow or blue dot inside piston (on new piston only) .475 in.
2 or 3 dots on end of wrist pin 12.025 mm

SORTING TABLE

Group	Wrist pin boss	Group	Wrist pin
	Diameter		Diameter
yellow	.4728 - .4727 in.	2	.4726 - .4724 in.
	12.008 - 12.006 mm		12.003 - 12.000 mm
blue	.4727 - .4726 in.	2	.4726 - .4724 in.
			12.003 - 12.000 mm
	12.006 - 12.003 mm	3	.4725 - .4723 in.
			12.000 - 11.997 mm

PISTON - CYLINDER

Piston-cylinder

Piston and cylinder are matched together and marked on the piston crown and on the joint surface of the cylinder top.

ALU-Cylinder and piston:

1,2,3,4 or 5 on piston crown
1,2,3,4, or 5 on cylinder head joint surface

Hi-Torque-Cylinder and piston:

11,22 or 33 on piston crown
11,22 or 33 on cylinder head joint surface

MAGNUM-Cylinder and piston:

1 or 2 on piston crown
1 or 2 on cylinder head joint surface.

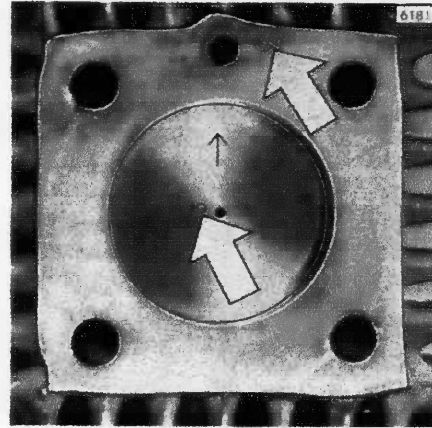

MAGNUM SORTING TABLE

Group	Cylinder Diameter	Piston Diameter
1	1,4961 in. - 1,4964 in. 38,001 mm - 38,008 mm	37,965 mm - 37,975 mm 1,4947 in. - 1,4951 in.
2	1,4964 in. - 1,4967 in. 38,008 mm - 38,016 mm	37,956 mm - 37,965 mm 1,4943 in. - 1,4947 in.

NOTE: The 0/size pistons are available for the Hi-Torque and MAGNUM-Cylinders only. The boring has to be done locally.

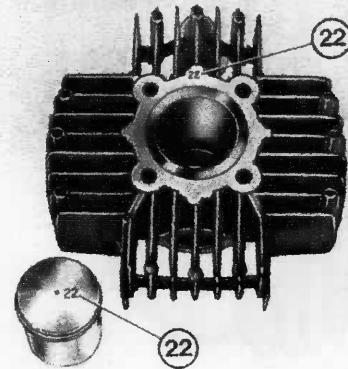

ALU-CYLINDER SORTING TABLE

Group	Cylinder diameter	Piston diameter
1	1.4950 - 1.4954 in. (37.975 - 37.985 mm)	1.4938 - 1.4942 in. (37.945 - 37.955 mm)
2	1.4954 - 1.4958 in. (37.985 - 37.995 mm)	1.4942 - 1.4946 in. (37.955 - 37.965 mm)
3	1.4958 - 1.4962 in. (37.995 - 38.005 mm)	1.4946 - 1.4950 in. (37.965 - 37.975 mm)
4	1.4962 - 1.4966 in. (38.005 - 38.015 mm)	1.4950 - 1.4954 in. (37.975 - 37.985 mm)
5	1.4966 - 1.4970 in. (38.015 - 38.025 mm)	1.4954 - 1.4958 in. (37.985 - 37.995 mm)

HI-TORQUE-CYLINDER SORTING TABLE

Group	Cylinder diameter	Piston diameter
11	1,4960 - 1,4963 in. (38,000 - 38,005 mm)	1,4944 - 1,4946 in. (37,956 - 37,965 mm)
22	1,4963 - 1,4965 in. (38,005 - 38,010 mm)	1,4946 - 1,4949 in. (37,965 - 37,970 mm)
33	1,4965 - 1,4968 in. (38,010 - 38,015 mm)	1,4949 - 1,4951 in. (37,970 - 37,978 mm)

PISTON - CYLINDER

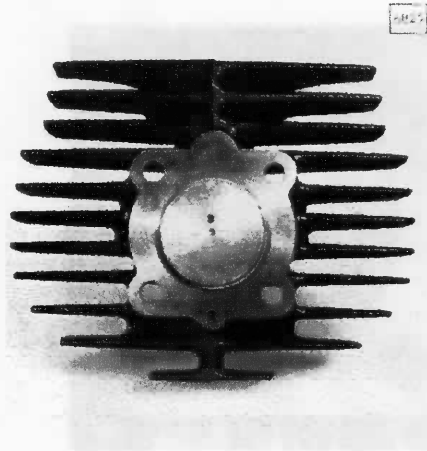

GROUP	CYLINDER DIAMETER
B	1.4960 in. (38.000 mm)
C	1.4963 in. (38.005 mm)
D	1.4965 in. (38.010 mm)

GROUP	PISTON DIAMETER
B	1.4940 in. (37.950 mm)
C	1.4942 in. (37.955 mm)
D	1.4944 in. (37.960 mm)

NOTE: O/size pistons are available. Boring has to be done locally.

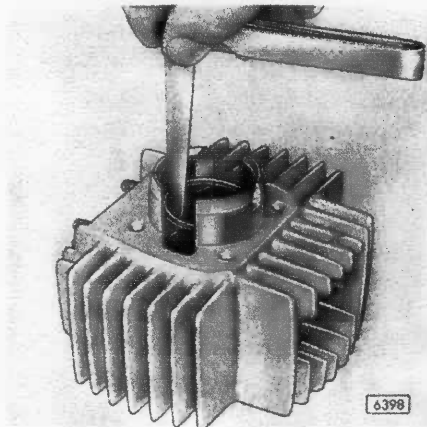

Piston/cylinder clearance limits

Ring gap

ALU-Cyl.: Min..0008 in. (0,020 mm) .006 - .012 in.

Max. .0016 in. (0,040 mm) 0,15 - 0,30 mm

Hi-Tor.-Cyl.: Min. .0014 in. (0,037 mm) (for all models)

Max. .0020 in. (0,052 mm)

MAGNUM-Cyl.: Min. .0014 in. (0,036 mm)

Max..0020 in. (0,052 mm)

CARST IRON-Cyl.: Min. .0020 in. (0,052 mm)

NOTE: When boring a cylinder for O/size piston, note piston sort type number, and refer to respective sorting table and add 0.25 mm to cylinder sorting (diameter) size.

EXAMPLE: O/size piston sorting group 22, cylinder diameter required 1.5061 - 1.5063 inches (38,256 - 38,261 mm).

Measuring the cylinder

The cylinder bore is measured with a bore gauge and a boremeasuring adapter (both items are commercially available).

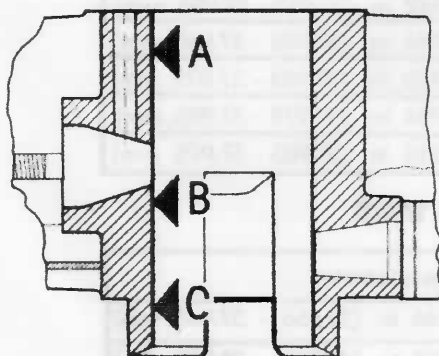

Maximum permissible ovality of cylinders:

ALU-Cylinder .0004 in. (0,01 mm)

Hi-Torque-Cyl. .0012 in. (0,03 mm)

MAGNUM-Cyl. .0012 in. (0,03 mm)

CARST-IRON-Cyl. .0012 in. (0,03 mm)

ASSEMBLE CRANKSHAFT - 1 SPEED

ASSEMBLING CRANKSHAFT (OLD TYPE)

Use special tool 905.0.33.104.1 between the two (2) crankshaft webs and special installation sleeve 350.1.70.012.0 to install flywheel side main bearing on crankshaft.

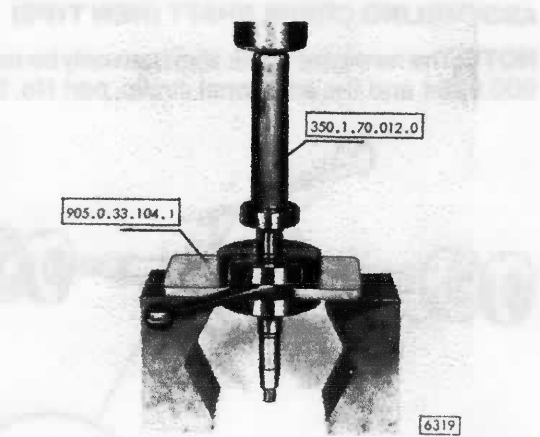
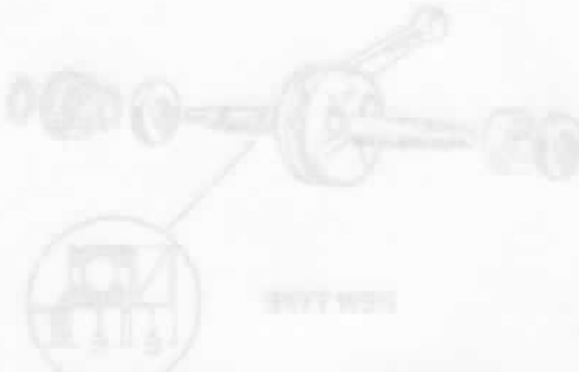

Lubricate oil seal and install crankshaft seal, sealing lips facing outward, on clutch side of crankshaft.

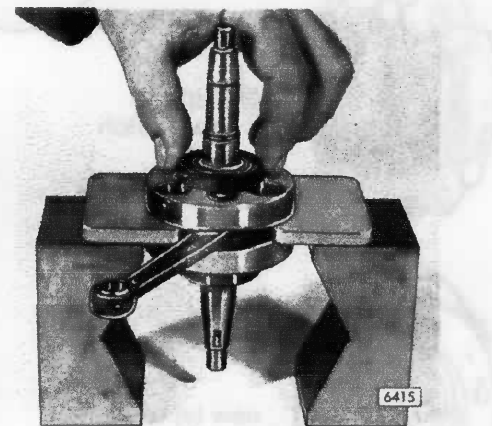

Again use installation sleeve 350.1.70.012.0 to press clutch side main bearing on crankshaft, with the locating ring groove facing the outside. Install retainer circlip.

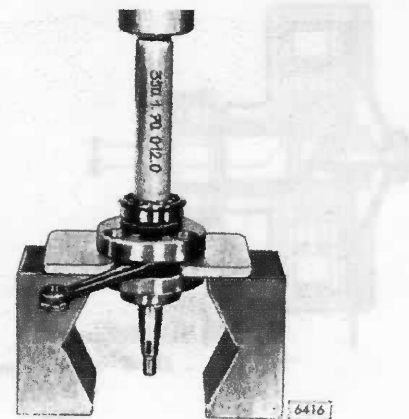

ASSEMBLE CLUTCH - 1 SPEED

ASSEMBLING CRANK SHAFT (NEW TYPE)

NOTE: The new type crank shaft can only be used in replacement with the new type main bearing, part No. 900.6254 and the additional circlip, part No. 900.4617.

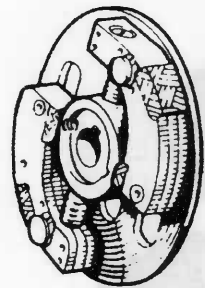
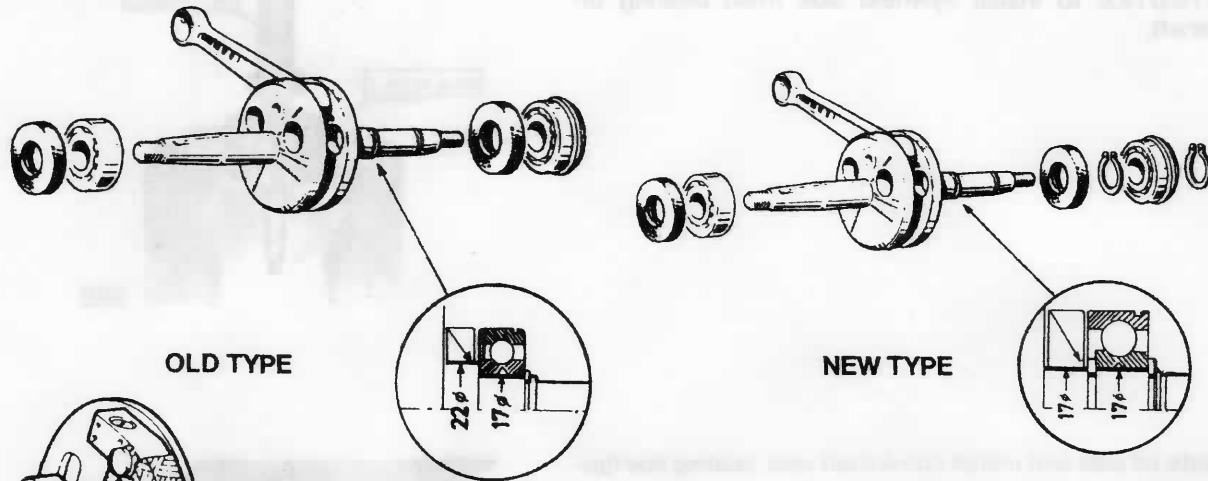

old type
2-shoe clutch

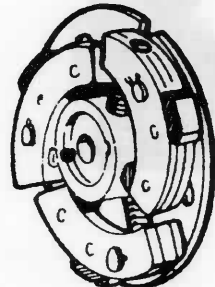

new type
3-shoe clutch

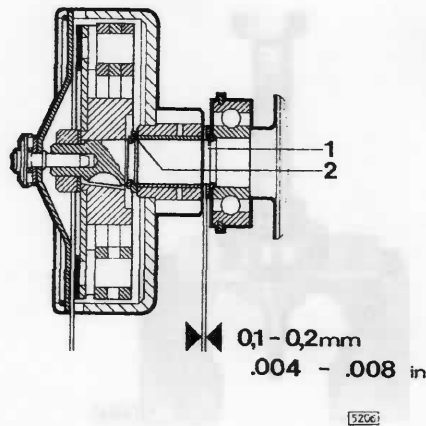

AUTOMATIC (ONE SPEED)

The automatic consists of a centrifugal clutch and a one (1) speed gear train.

Starting engine: engaging the pressure plate with the centrifugal clutch (face lining) will give a solid drive between crankshaft and clutch drum.

Centrifugal clutch starts to open at appr. 1200-1500 rpm. Fully engaged at appr. 2600-3000 rpm and is disengaging between 1400-1150 rpm.

Centrifugal clutch must be replaced when linings are worn and limit pins (on shoes) prevent drum contact.

NOTE: The old 2-shoe clutch hub has been replaced by the new 3-shoe type hub. At the same time the woodruff key is no longer being used on the clutch hub.

CLUTCH DRUM END-FLOAT

The end-float of the clutch drum on the crankshaft must be between .004 - .008 in. (0,10 - 0,20 mm). This clearance is achieved by various sizes of upper and lower shims (1 and 2). The correct adjustment procedure is outlined in the following steps.

Install clutch drum bushing, inner shim, clutch drum and retainer circlip (do not install outer shim as yet).

ASSEMBLE CLUTCH - 1 SPEED

Firmly hold clutch drum against circlip, measure gap between primary gear and inner shim on crankshaft (not circlip on bearing). Measure gap with feeler gauge. From this measurement deduct end-float required of clutch drum. This will give required outer shim size.

EXAMPLE: Gap measured .079 in (2.0 mm)
minus required end-float .004 in (0.1 mm)

Required outer shim for .004 in end-float = .075 in (1,9 mm)

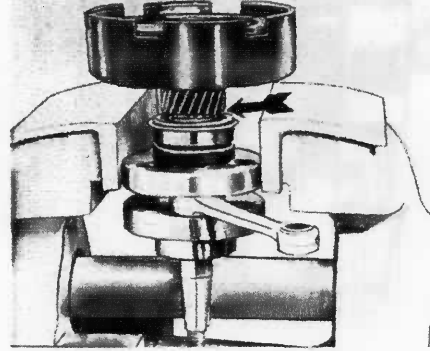

Once the required shim is established, remove clutch drum and reassemble with shims. Torque nut to 20 ft/lb (27 Nm).

Replace pressure plate and secure with large retaining ring.

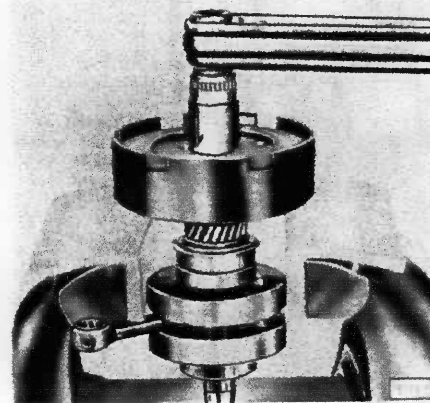

NOTE: The same adjusting procedure is being used for the new type clutch.

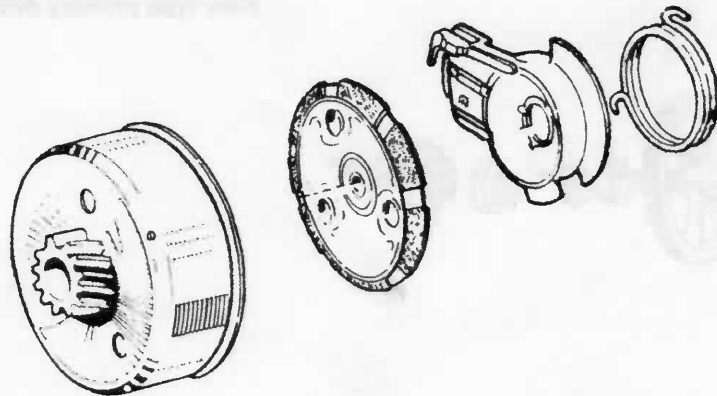

ASSEMBLE ENGINE - 1 SPEED

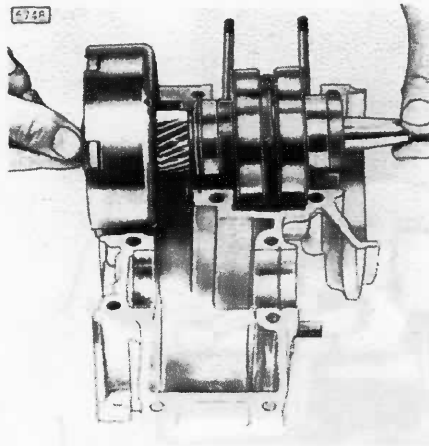

ASSEMBLING ENGINE:

Lubricate magneto side oil seal and install with sealing lip facing inwards.

⚠ Ensure sufficient gap between magneto side bearing and oil seal appr. 0.040 in. (1 mm) to allow oil flow to bearing. Install crankshaft and clutch assembly in housing half.

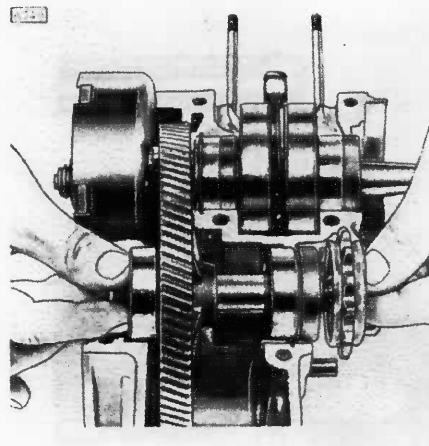

Reassemble primary drive, lubricate seal and install with sealing lip facing outward. Place assembly in crankcase half.

NOTE: Assure that locating rings (on crankshaft clutch side main bearing and primary drive, between bearing and seal) have their gaps face straight up.

Sparsingly apply sealing compound (non-hardening) to crankcase joint, fit crankcase half into place and torque crankcase screws to 6 ft/lb (8 Nm).

AUSTRO DAIMLER and DART

New type primary drive with free wheel pawl.

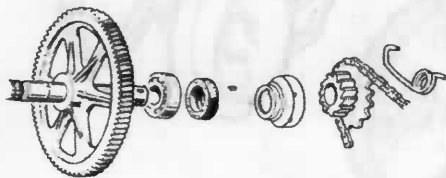

ASSEMBLE ENGINE - 1 SPEED

Place engine in upright position, oil small end bushing and install piston. Ensure the arrow on the piston crown and ring locating pins are facing the exhaust (drain plug) side.

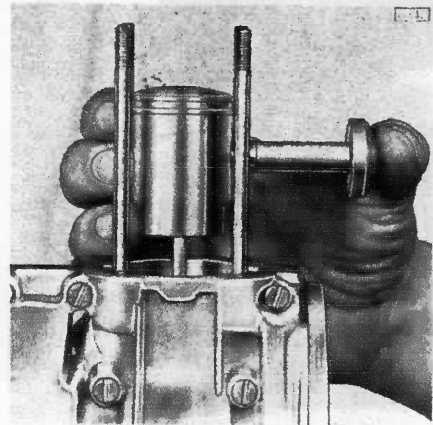

Fit a new cylinder base gasket into place, lightly oil piston and cylinder wall and replace cylinder.

! Be sure to align ring gap to their respective locating pins.

NOTE: The exhaust port of the cylinder should face drain plug side of engine.

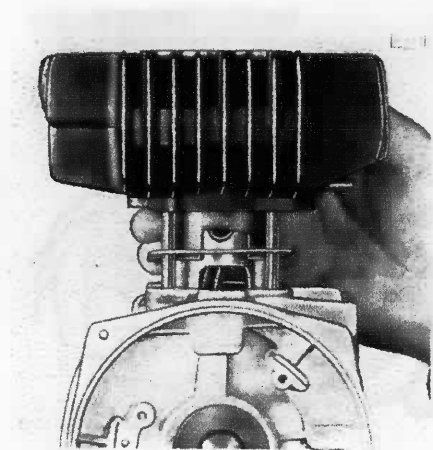

Where applicable, place proper cylinder head gasket into position. Fit head and washers and torque cylinder head nuts to 7 ft/lb (10 Nm).

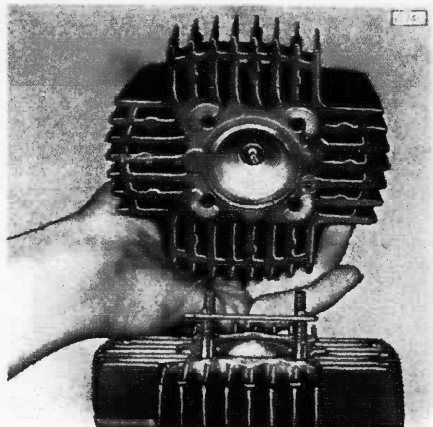

ASSEMBLE / INSTALL ENGINE - 1 SPEED

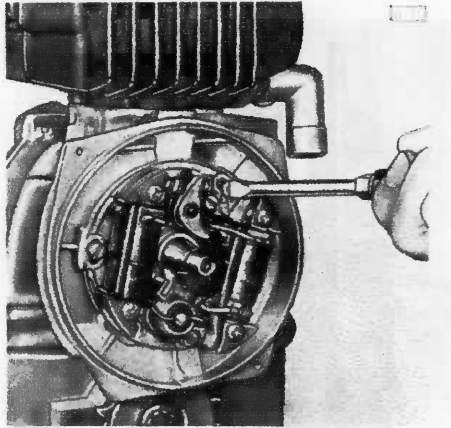

Inspect contact breaker points for burning, pitting or wear and replace if necessary. Inspect coils and wires for cuts and loose connections.

Feed magneto wires through crankcase opening and replace rubber grommet. Install generator stator plate assembly so that the locating screws are in the center of the locating holes.

NOTE: Ensure no wires are squeezed between stator plate assembly and housing.

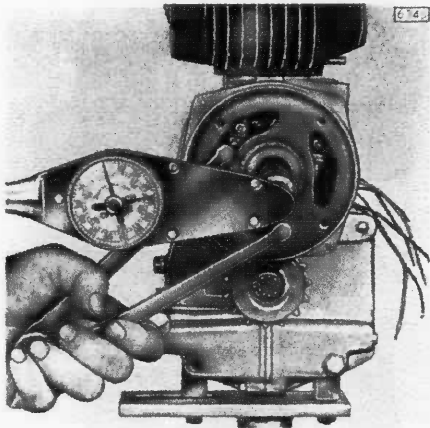

Clean crankshaft taper, fit woodruff key into keyway, install flywheel. Use locking device 905.0.16.101.2 to lock flywheel and torque nut to 25 ft/lb (35 Nm). Before replacing generator cover set ignition timing (see page 111).

Install a new gasket and replace clutch cover. Torque screws to 6ft/lb (8 Nm).

Grease and replace kickstand. Torque bearing shell retaining bolts to 6 ft/lb (8 Nm).

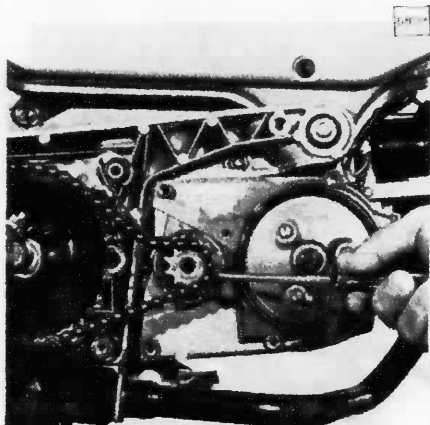

Install engine in frame A-D Series

Place pedalling chain over drive sprocket and install drive sprocket into free-wheel pawl. Put chain tensioner into position.

Fit new clutch cover gasket, hook-up clutch cable to raiser bearing and instal clutch cover. Torque screws 6 ft/lb (8 Nm).

INSTALL ENGINE - 1 SPEED

Torque engine mounting bolts to 23 ft/lb (32 Nm).
A-D Series to 29 ft/lb (40 Nm).

MAXI-SERIES

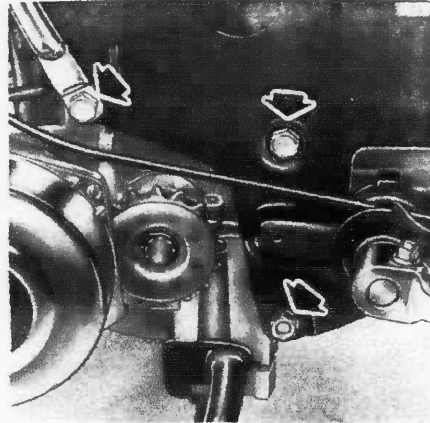

A-D SERIES

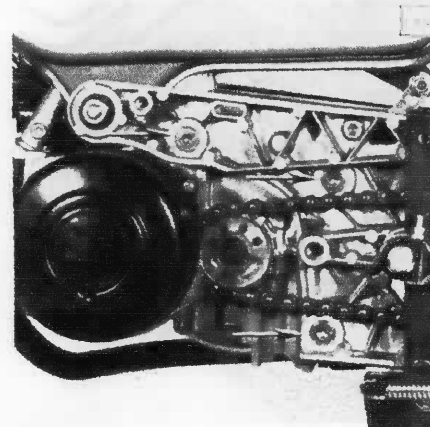

Fit starter cable.

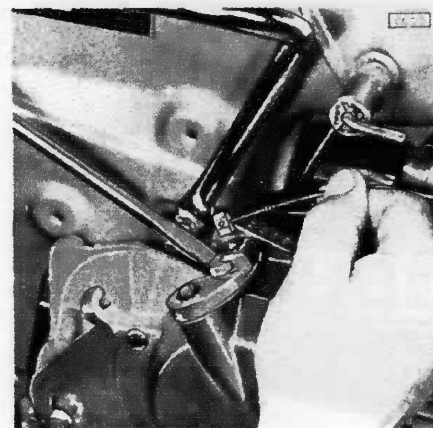

INSTALL ENGINE - 1 SPEED

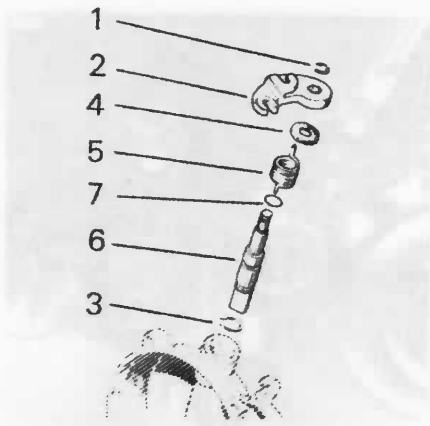

CLUTCH LEVER AND SHAFT

Drain transmission fluid, remove kickstand spring, and clutch cover. Remove upper circlip (1), clutch lever (2), lower circlip (3), seal ring (4) and spring (5). After removing the clutch shaft (6) check housing and shaft for excessive wear. Always replace „O” ring (7) and seal ring (4).

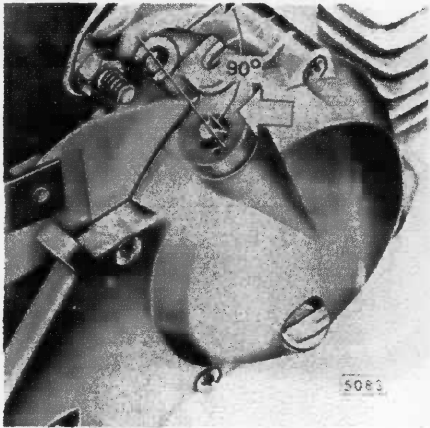

When fitting the starter lever ensure the lever is installed correctly. Before the starter clutch engages fully, the lever should form a right angle with the starter cable.

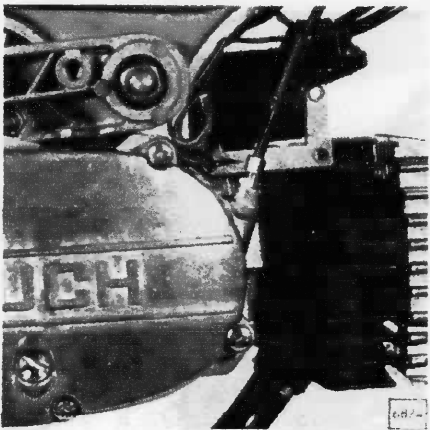

A-D and Dart Series: Hook-up starter cable at starter lever and adjust the cable to have approx. $\frac{3}{4}$ in. (2 cm) free play at the lever.

INSTALL ENGINE - 1 SPEED

Reconnect electrical wires at junction block. Match color codes, see wiring diagrams on page 117.

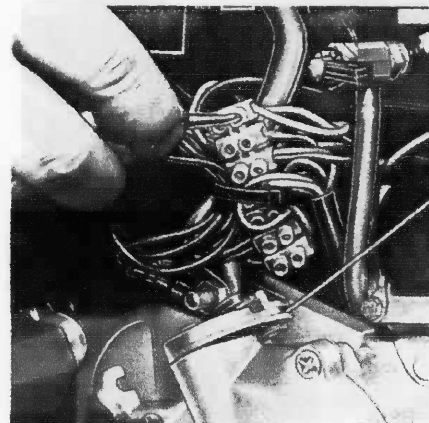

Fit a new exhaust gasket and replace exhaust system.

Install drive chain, take care that the tension is correct and the connecting link is properly placed with the closed end pointing in the direction of chain travel. The proper slack of the drive chain is $\frac{3}{4}$ in. (2 cm). To adjust tension, loosen axle nuts and tighten or loosen rear adjuster nuts. Once the drive chain is properly adjusted, tighten axle nuts. Make sure wheels are in alignment (for further information see page 97)

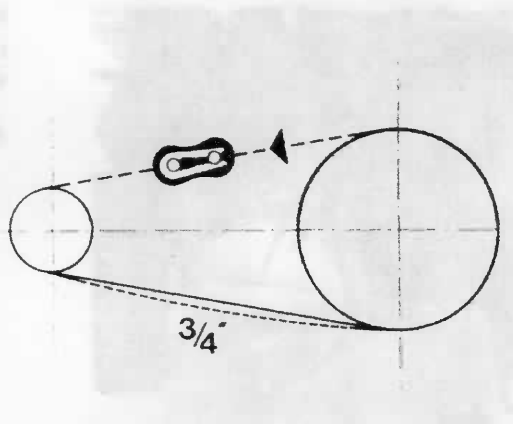

Replace carburetor, install fuel supply hose and fit air filter assembly.



Do not push intake hose too deeply into filter assembly as this could cause air flow restriction.

AUSTRO-DAIMLER air cleaner assembly (see page 9)

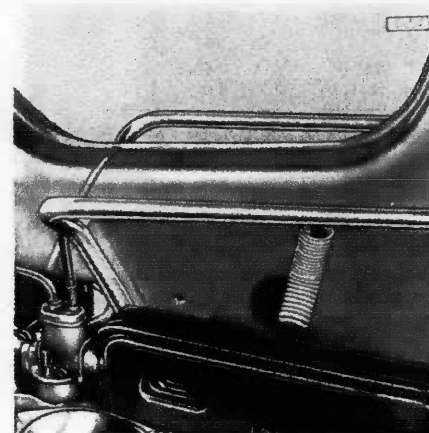

INSTALL ENGINE - 1 SPEED

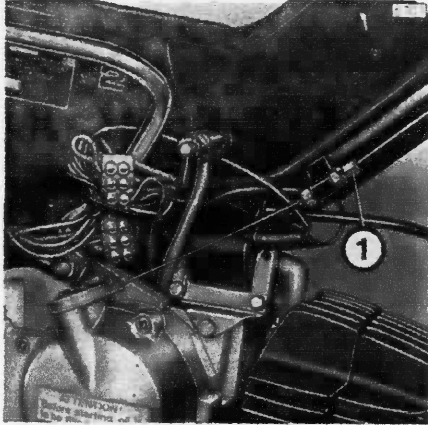

Adjust starter cable with adjusting screw (1).

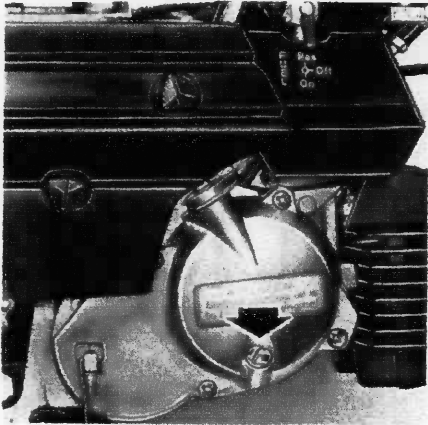

Remove filler plug and fill transmission with Automatic Transmission fluid "Type F" 5¾ fl. oz. (170 cc), until fluid is level with filler hole.

! Use only "Type F" Transmission fluid. Other types of fluid may dissolve clutch friction material.

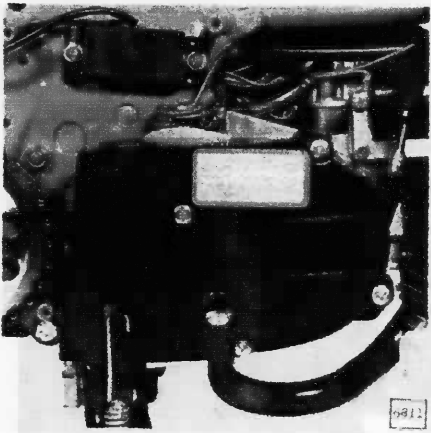

DART and AUSTRO-DAIMLER, 1-Speed, 6¾ fl.oz. (200 cc)
COBRA, 5¾ fl.oz. (170 cc)

INSTALL ENGINE - 1 SPEED

Free play at the starter lever (measured at the end of the lever) should be $\frac{3}{4}$ in. (2cm).

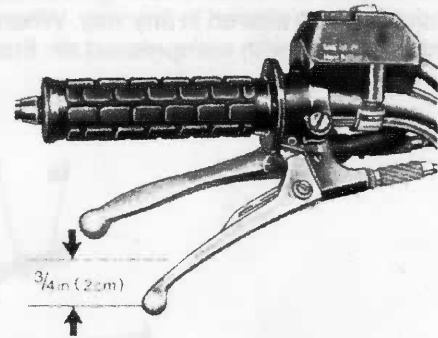

Adjust idle speed and throttle cable:

Start engine and run at moderate speed until operating temperature is reached. Adjust idle speed between 800 – 1200 rpm. Adjust throttle cable slack to .040 in. (1 mm) on adjusting screw (2) and tighten lock nut (1). See page 12 for further information.

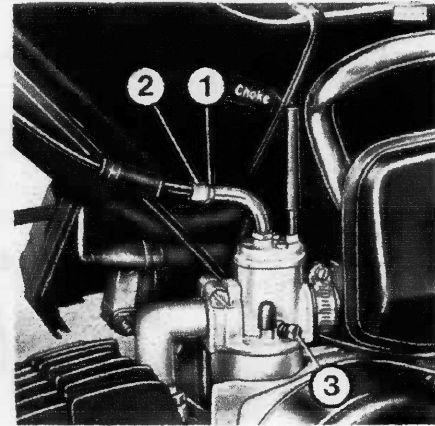

AUSTRO DAIMLER Series: For throttle cable and choke cable adjustments (see page 12).

- (1) Throttle cable
- (2) Choke cable

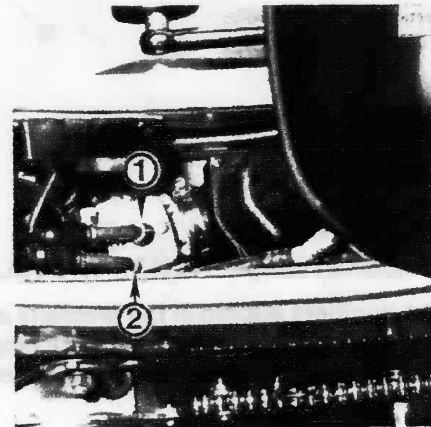

CARBURETOR

CARBURETOR (old Type)

The carburetor fitted to the engine is tuned to specifications established by intensive factory research and should not be altered in any way. Whenever dismantling a carburetor, clean all components with solvent and blow thru with compressed air. Ensure that the seating of the inlet needle is correct.

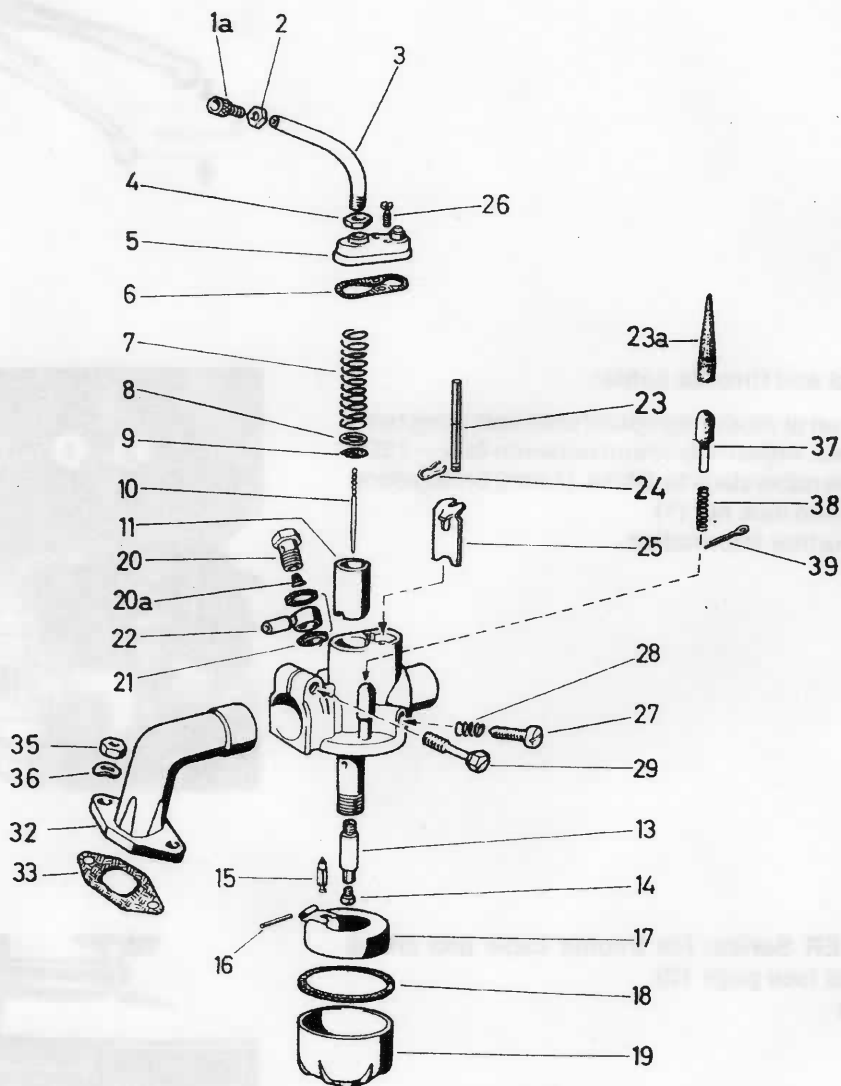

CARBURETOR OPERATION TROUBLE SHOOTING TIPS

(The numbers quoted in the brackets on page 56 refer to the illustration).

The carburetor on your MOPED is a Bing variable venturi (slide type) carburetor. The term variable venturi comes from the fact that the slide varies the amount of the restriction of air through the throat of the carburetor.

CARBURETOR

CARBURETOR (new Type)

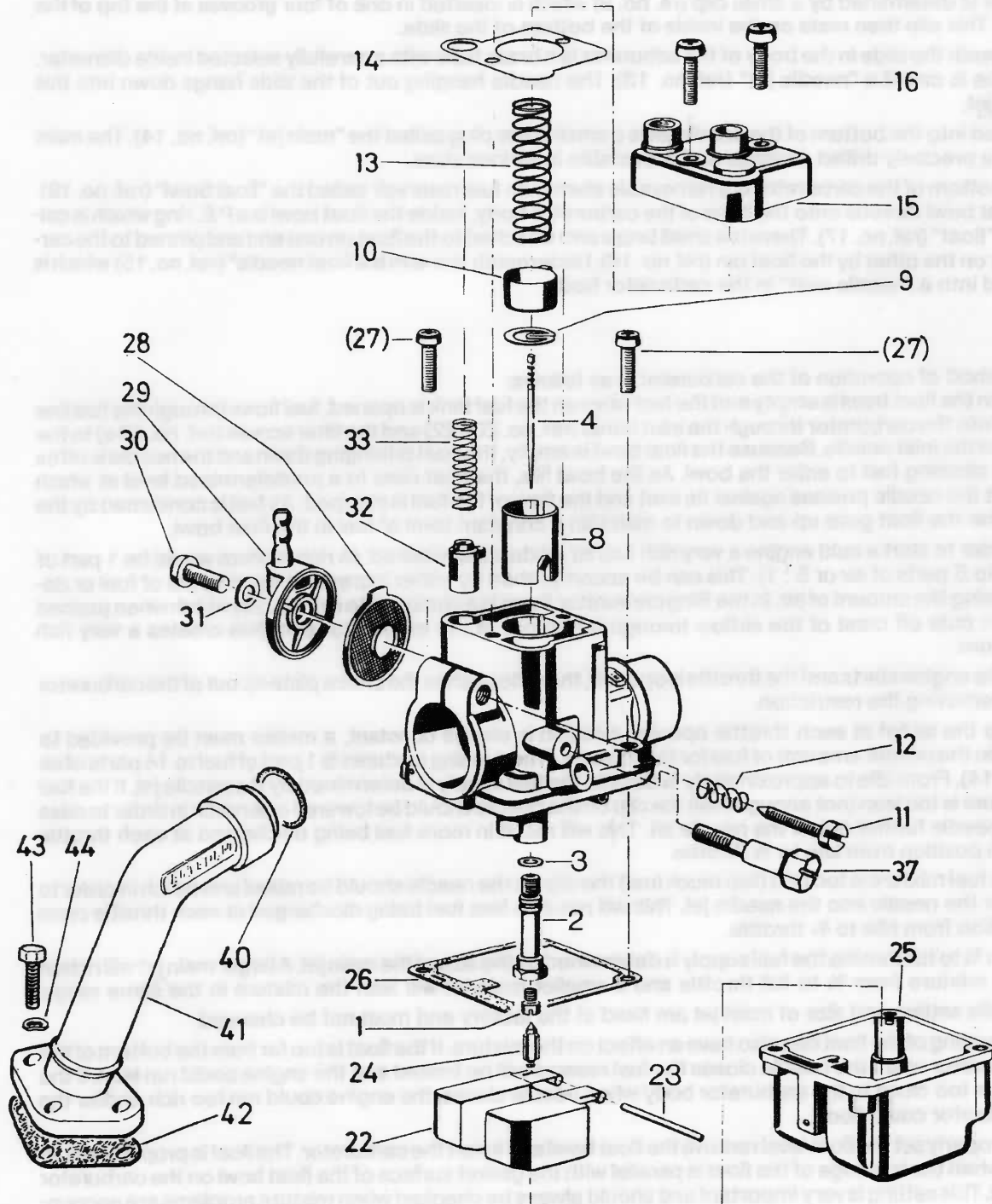

CARBURETOR

The components in the carburetor are simple. The slide (ref. no. 11) is attached to a cable which is operated by the twist grip on the handlebar. Turning the twist grip either raises or lowers the slide and this in turn either increases or decreases the amount of air allowed to flow through the throat of the carburetor.

Protruding from the bottom of the slide is a tapered rod or "needle" (ref. no. 10). Its position in relation to the slide is determined by a small clip (re. no. 9) which is inserted in one of four grooves at the top of the needle. This clip then rests on the inside of the bottom of the slide.

Underneath the slide in the body of the carburetor is a brass tube with a carefully selected inside diameter. This tube is called a "needle jet" (ref. no. 13). The needle hanging out of the slide hangs down into this needle jet.

Threaded into the bottom of the needle jet is a small brass plug called the "main jet" (ref. no. 14). The main jet has a precisely drilled passage and is available in various sizes.

At the bottom of the carburetor is a removable aluminum fuel reservoir called the "float bowl" (ref. no. 19). The float bowl threads onto the base of the carburetor body. Inside the float bowl is a P.E. ring which is called the "float" (ref. no. 17). There is a small brass arm attached to the float on one end and pinned to the carburetor on the other by the float pin (ref. no. 16). Underneath this arm is a float needle" (ref. no. 15) which is inserted into a "needle seat" in the carburetor body.

The method of operation of the carburetor is as follows:

1. When the float bowl is empty and the fuel valve on the fuel tank is opened, fuel flows through the fuel line and into the carburetor through the inlet banjo (ref. no. 20-22) and the filter screen (ref. no. 20 a) to the top of the inlet needle. Because the float bowl is empty, the float is hanging down and the needle is off its seat allowing fuel to enter the bowl. As the bowl fills, the float rises to a predetermined level at which point the needle presses against its seat and the flow of the fuel is stopped. As fuel is consumed by the engine the float goes up and down to maintain a constant level of fuel in the float bowl.

2. In order to start a cold engine a very rich fuel air mixtures is required. (A rich mixture would be 1 part of fuel to 5 parts of air or 5 : 1). This can be accomplished by either increasing the amount of fuel or decreasing the amount of air. In the Bing carburetor there is a choke plate (ref. no. 25) which when pushed down cuts off most of the airflow through the throat of the carburetor and thus creates a very rich mixture.

When the engine starts and the throttle is opened, the slide pushes the choke plate up out of the carburetor throat removing the restriction.

3. Since the airflow at each throttle opening position is always constant, a means must be provided to obtain the proper amount of fuel for the mixture. (The running mixtures is 1 part of fuel to 14 parts of air or 1:14). From idle to approximately $\frac{3}{4}$ throttle the fuel supply is determined by the needle jet. If the fuel mixture is too lean (not enough fuel) the clip on the needle should be lowered one notch in order to raise the needle further out of the needle jet. This will result in more fuel being discharged at each throttle open position from idle to $\frac{3}{4}$ throttle.

If the fuel mixture is too rich (too much fuel) the clip on the needle should be raised one notch in order to lower the needle into the needle jet. This will result in less fuel being discharged at each throttle open position from idle to $\frac{3}{4}$ throttle.

From $\frac{3}{4}$ to full throttle the fuel supply is determined by the size of the main jet. A larger main jet will richen then mixture from $\frac{3}{4}$ to full throttle and a smaller main jet will lean the mixture in the same range.

Needle setting and size of main jet are fixed at the factory and must not be changed.

4. The setting of the float can also have an effect on the mixture. If the float is too far from the bottom of the carburetor when the needle closes the fuel reserve will be limited and the engine could run lean. If the float is too close to the carburetor body when needle closes, the engine could run too rich and/or the carburetor could flood.

To properly set the float level remove the float bowl and invert the carburetor. The float is properly adjusted when the top edge of the float is parallel with the gasket surface of the float bowl on the carburetor body. This setting is very important and should always be checked when mixture problems are encountered.

DISMANTLE ENGINE - 2 SPEED

REMOVE ENGINE

Drain transmission oil.

Disconnect starter cable on starter lever, then follow the same procedure to remove the engine as previously outlined with the 1-speed engine.

! (If engine removed, but not completely dismantled). Do not turn starter clutch adjusting sleeve on engine as this would alter clearance adjustment on starter plate.

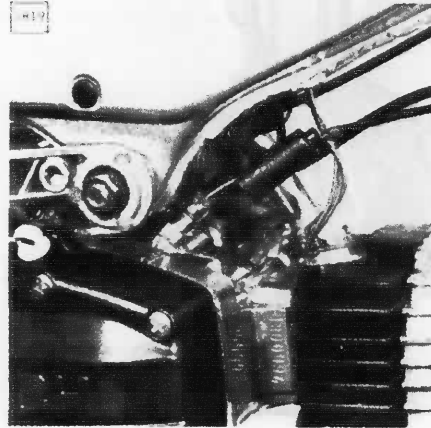

NOTE: MAGNUM MK II, disconnect oil supply line from oil pump and block-off supply line to avoid oil drainage from oil tank.

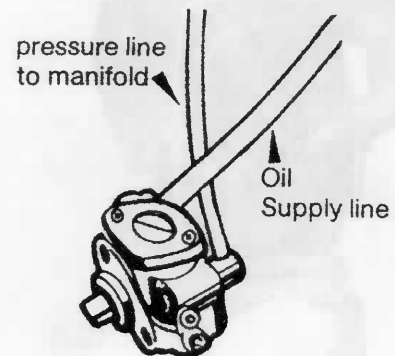

DISMANTLE ENGINE

Follow the same dismantling procedures as outlined on previous pages. Remove clutch cover, gasket, locating sleeves, main shaft and clutch drum shims and roller retainer thrust plate on main shaft. Inspect bearings inside clutch cover. To remove bearings, use special puller no. 905.0.14.002.0, 905.0.14.017.0 and 905.0.14.006.0, if not available, heat cover to appr. 170° F (80° C) and tap cover on workbench.

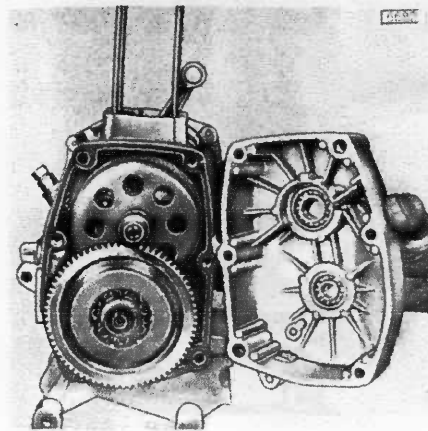

DISMANTLE ENGINE - 2 SPEED

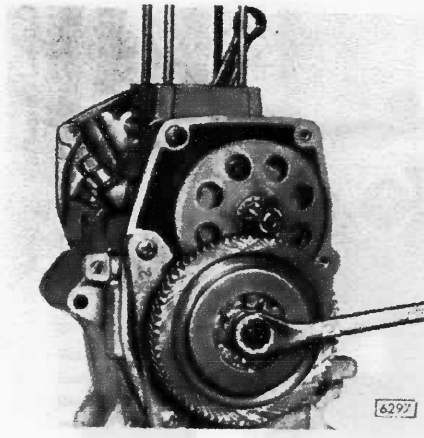

Lock second gear main shaft with tool 905.6.36.109.2 and remove retaining nut on main shaft.

! Left hand thread.

NOTE: By loosening retainer nut and spinning first speed gear, the nut and roller pack will remove as a unit.

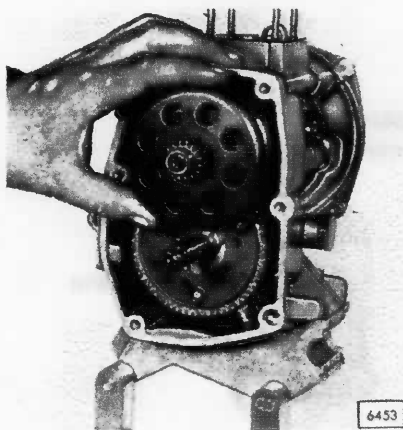

Remove clutch drum.

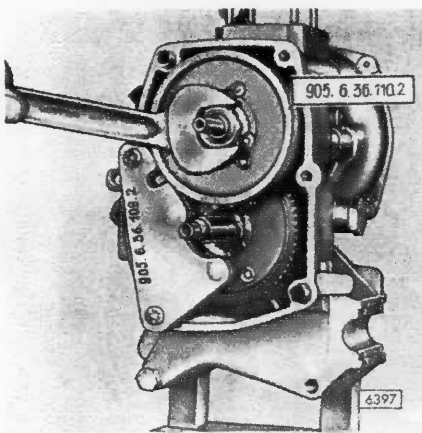

Open lock washer, place locking device 905.6.36.110.2 over centrifugal clutch and interlock with tool 905.6.36.109.2 and remove retainer nut.

DISMANTLE ENGINE - 2 SPEED

Remove first speed centrifugal clutch.

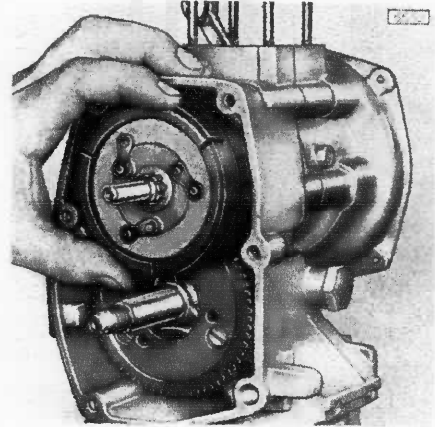

Remove clutch spacer.

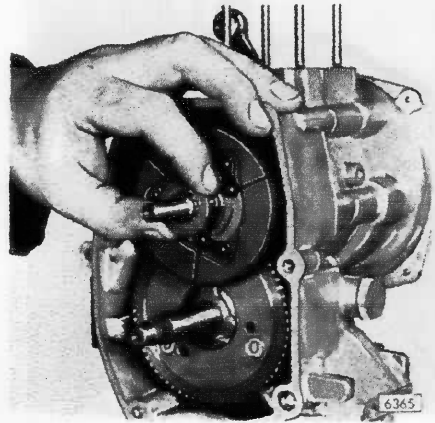

Lift off second speed centrifugal clutch.

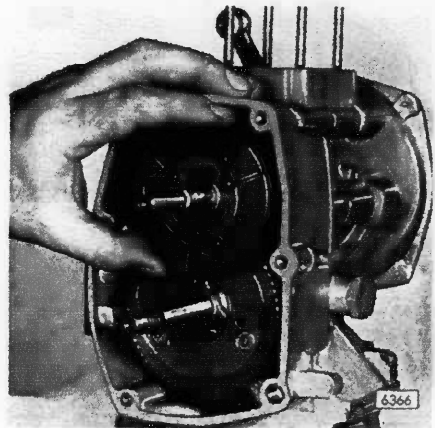

DISMANTLE ENGINE - 2 SPEED

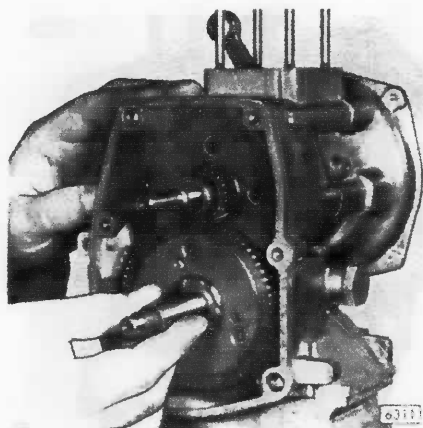

Remove main shaft

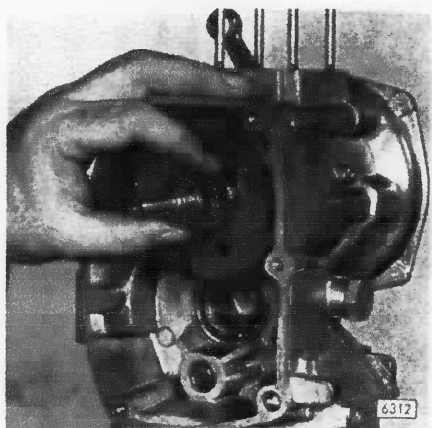

and second speed-driving plate.

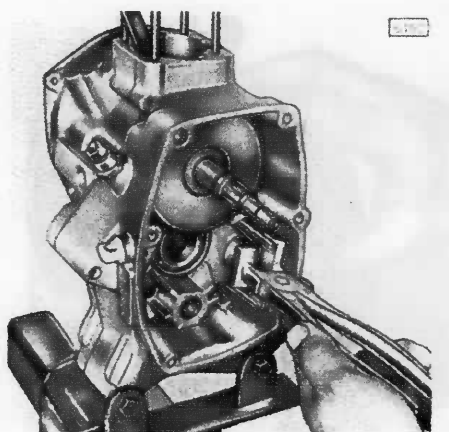

With special pliers 905.6.41.101.2 remove retainer spring.

DISMANTLE ENGINE - 2 SPEED

Remove circlip, washer, spring and starter plate from crankshaft. Remove clutch adjusting nut, short starting cable and engaging plate.

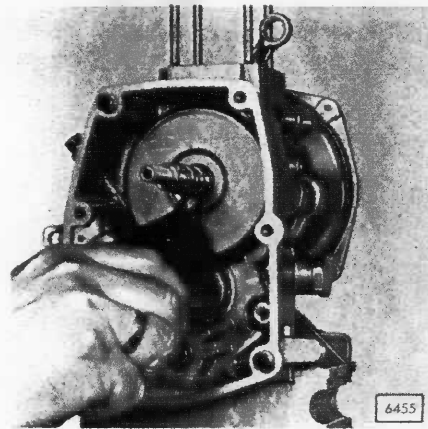

Place engine on assembly table 905.0.31.101.2 and remove all housing screws. Separate housing halves. Lift crankshaft from lower crankcase half. Remove gasket and both housing dowels.

NOTE: During engine overhaul it is important to replace all seals.

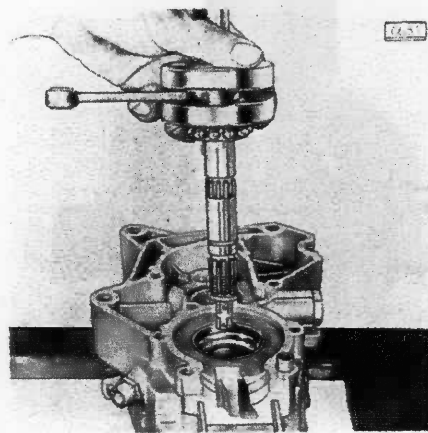

AUSTRO DAIMLER Series: Before removing the drive shaft "A", remove the starting mechanism "B" and drive sprocket assembly "C".

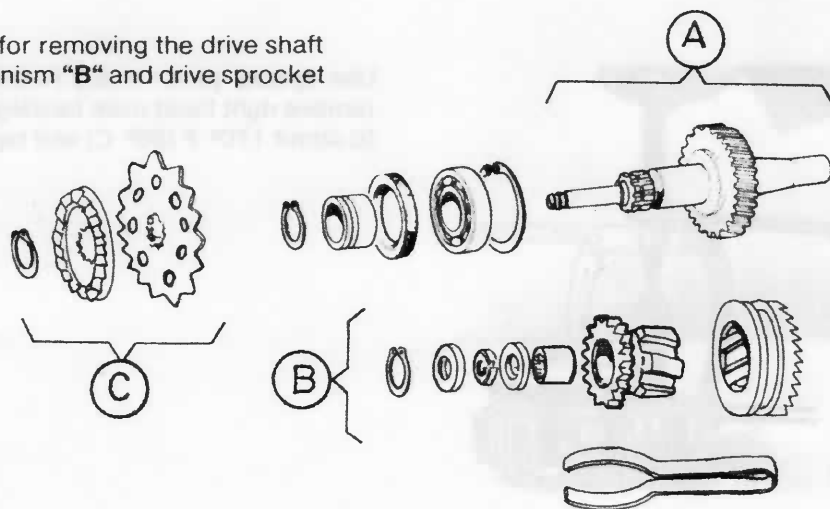

DISMANTLE ENGINE - 2 SPEED

6145

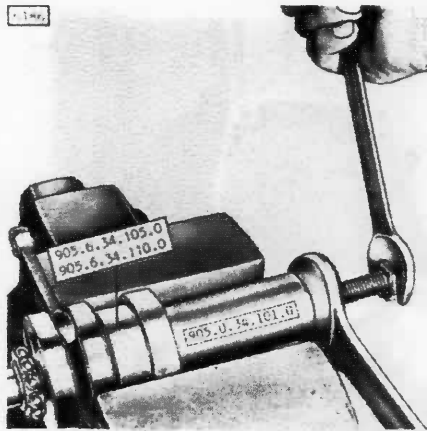

Remove main bearing with special puller 905.0.34.101.0 for the generator side use puller cages 905.6.34.105.0 and puller cages 905.6.34.110.0 for the clutch side.

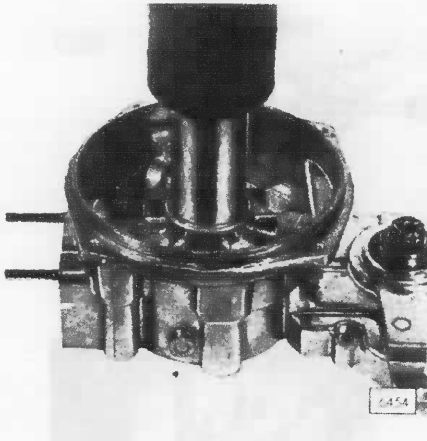
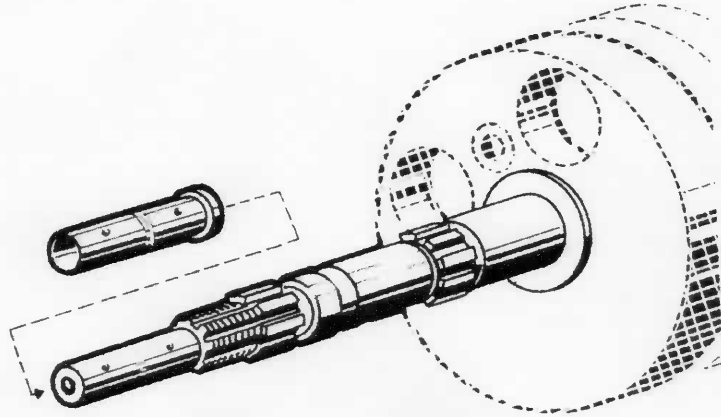

Inspect crankshaft and carry out all inspection and repair works as outlined in previous pages under "Crankshaft".

NOTE: If the crankshaft bushing is twisted and the oil supply holes are blocked or there are noticeable signs of abnormal wear, remove the bushing and replace with:

MAXI: Up to serial no. 5334443 part no. 321.1.12.617.3
 From serial no. 5334444 part no. 321.2.12.617.3
 MAGNUM: Up to serial no. 1602230 part no. 321.1.12.617.3
 From serial no. 1602231 part no. 321.2.12.617.3

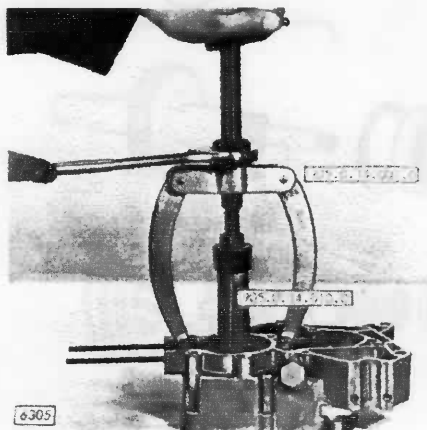

Use special puller 905.0.14.010.0 and 905.0.14.001.0 to remove right hand main bearing cup or heat-up crank case to about 170° F (80° C) and tap case to workbench.

DISMANTLE OIL PUMP DRIVE

ENGINE WITH OIL PUMP MAGNUM MK II

Dismantling:

Follow same engine dismantling procedure as outlined under "dismantle engine". Disconnect oil line from inlet manifold.

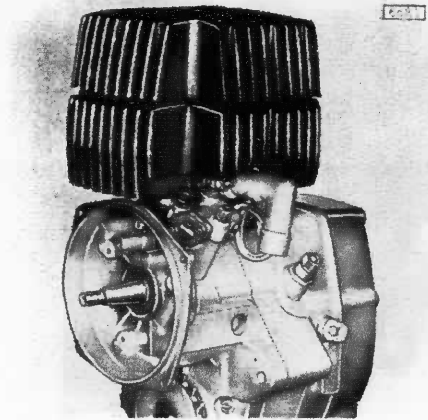

Remove oil pump and gasket from left housing half.

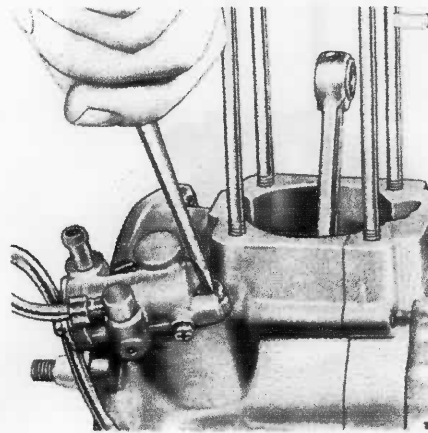

The oil pump is a non-repairable part and has to be replaced as a unit. It is a factory metered unit to obtain the correct lubrication ratio for the engine. It delivers 1.35 fl. oz (40 cc) at 1500 rpm per hour.

Testing oil pump delivery:

Fill gas tank with regular gasoline pre-mix. Remove oil pressure hose from intake manifold, place hose in a measuring container. Run engine for 4 1/2 min at 3500 rpm. Oil pump should deliver .0338 fl. oz \pm .003 (10 cc \pm 0,10). Repeat test at least once, if oil pump does not deliver required amount, replace oil pump assembly.

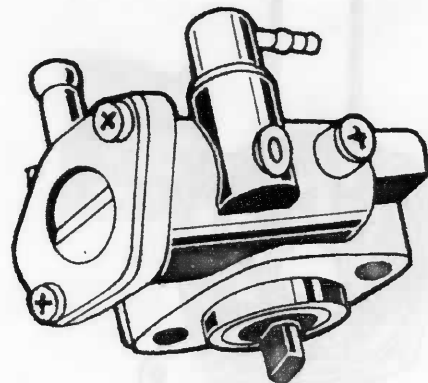

DISMANTLE OIL PUMP DRIVE

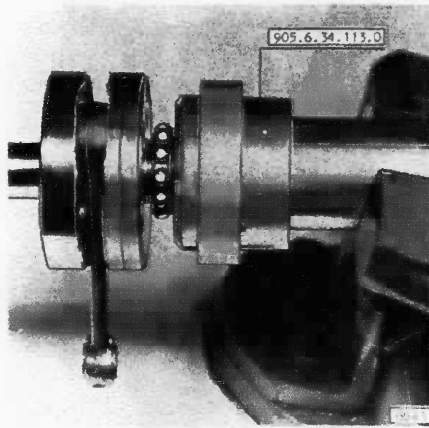

Having the engine completely dismantled, remove oil pump drive gear from crankshaft. Using puller 905.0.34.101.0 and cages 905.6.34.113.0.



Do not lose drive gear locating pin.

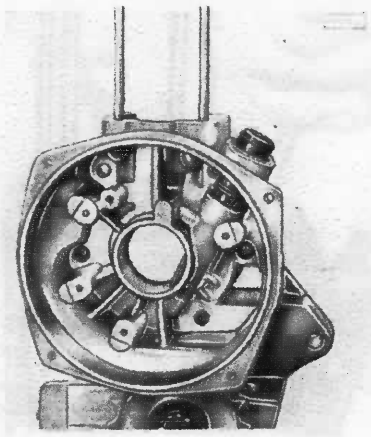

Remove crankshaft oil seal and drive shaft guide sleeve from housing half.

NOTE: Always replace "O" rings on guide sleeve to avoid leakage from crankcase.

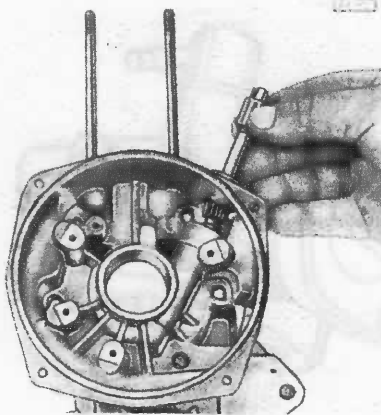

Remove oil pump drive shaft and check for wear.
Do not lose thrust washers of lower end of drive shaft.

ASSEMBLE ENGINE - 2 SPEED

After the correct measurement has been obtained, place shim(s) on the crankshaft and press on inner bearing ring. (Bearing identification marks facing outward on crankshaft). Using installation sleeve no. 905.6.33.111.2 (clutch side) and no. 350.1.70.012.0 (generator side), place special plate no. 905.0.33.104.1 between crank webs to prevent damage to crankshaft.

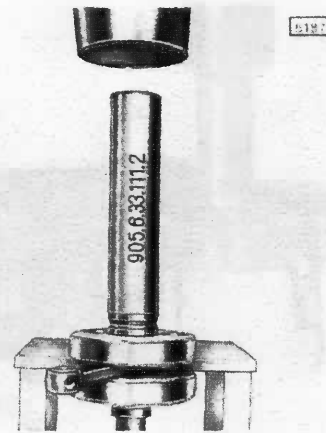

Place protecting sleeve 905.6.31.108.1 over crankshaft (clutch side) and install shaft in right hand housing half. Fit both hollow dowels and place new gasket on housing.

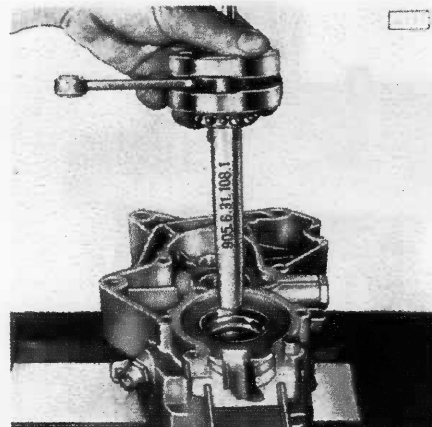

If bearing has been removed, install bearing and circlip. Install seal and drive shaft in left housing half.

AUSTRO DAIMLER Series: drive shaft.

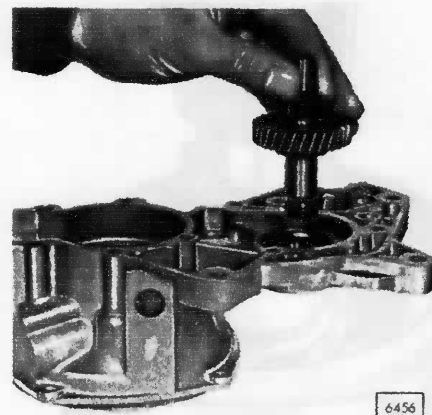
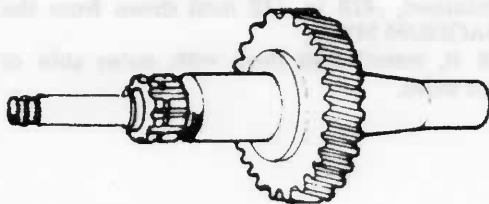

ASSEMBLE ENGINE - 2 SPEED

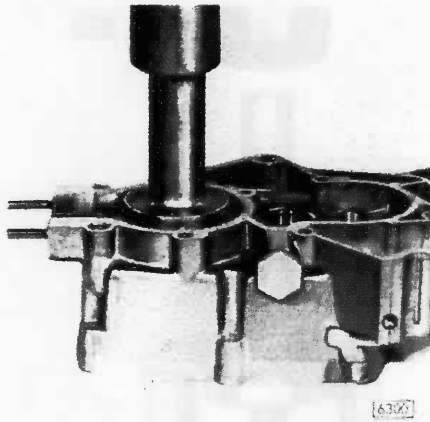

To install new bearing cups, warm up housing halves to approx. 170° F (80° C) and press in bearing cups.

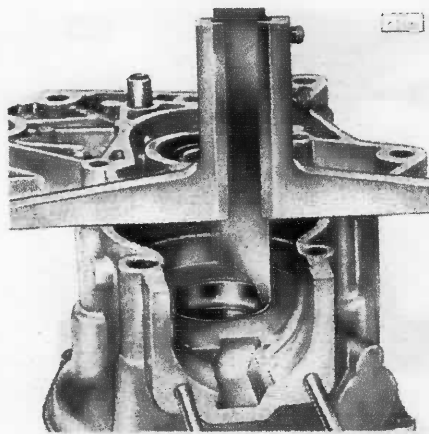

After installation of bearing cup measure with a depth gauge on four opposite points of the perimeter to ensure cup is squarely seated.

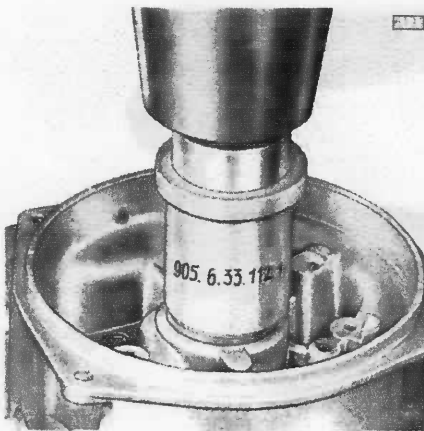

Installations of seals

Left hand crankcase half:

Crankshaft and drive shaft seals are pressed into position with the sealing lips facing inwards using tool no. 905.6.33.112.1.

A double lip seal is used in the left hand (generator side) crankcase half. Lubricate seal lips before installation.

With using this special seal-installer, the correct installation position will be obtained, .472 in. (12 mm) down from the upper edge (not MAGNUM MK II).

On MAGNUM MK II, install seal flush with outer side of crankcase (magneto side).

ASSEMBLE ENGINE - 2 SPEED

Install starter plate, spring, washer and circlip.

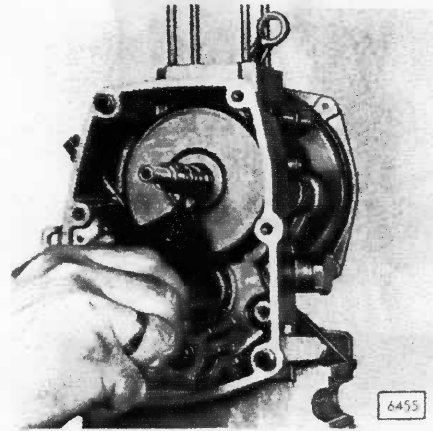

Install engaging plate return spring using tool no. 905.6.41.101.2.

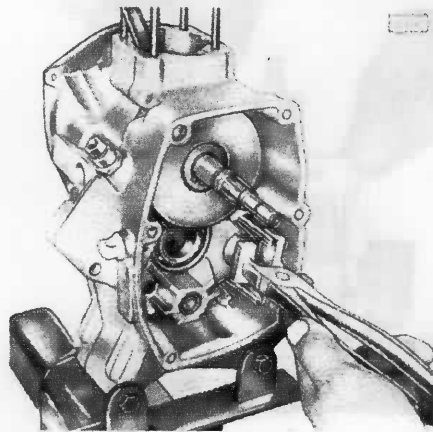

Place thrust washer on crankshaft.

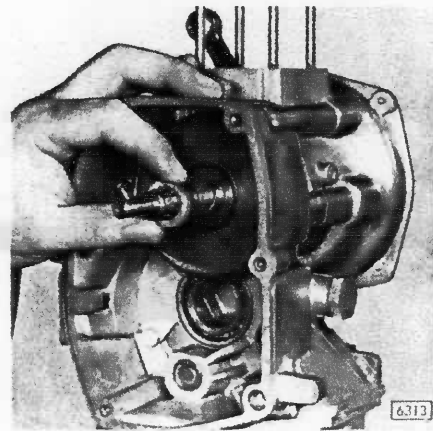

ASSEMBLE ENGINE - 2 SPEED

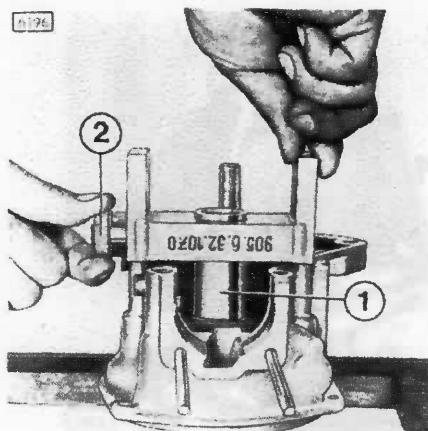

Put the bearing inner race with the cage into the left crankcase half (bearing identification marks facing downward) and set up the measuring device no. 905.6.32.107.0 as shown. Adjust the tool measuring sleeve (1) into the inner bearing race and locate in position with the setscrew (2).

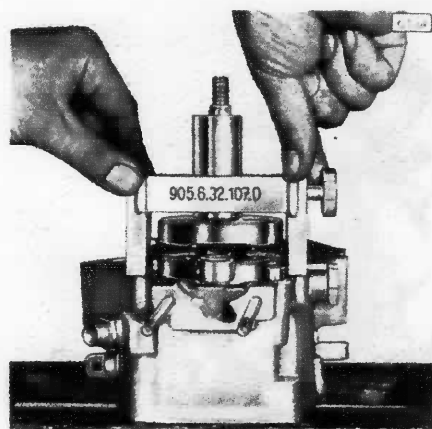

Take off gauge, and invert before positioning over the crankshaft.

Compensate for the clearance between the measuring sleeve and the ground bearing stop on the crankshaft journal by using shims.

These shims are available in the thickness of:
 .002; .004; .008; .012 in. (0,05; 0,10; 0,20; 0,30 mm) magneto side
 .004; .008 in. (0,10 and 0,20 mm) clutch side.

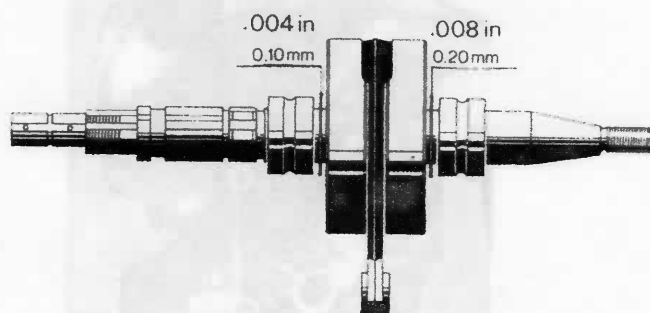

Adjustment hint:

The specified end float of .002 - .006 in. (0,05 - 0,15 mm) is obtained when the crankshaft slightly touches the gauge with the gauge pressed firmly on the gasket.

If the thickness of the shim needed is beyond .008 in (0,20 mm) in the one side, then the shims must be apportioned equally to the left and right hand sides.

ASSEMBLE OIL PUMP DRIVE

Assembling:

After completion of all repair work on engine and end-float adjustment of crankshaft, place oil pump drive gear over crankshaft end.



Ensure that drive gear locating slot and locating pin are in line.

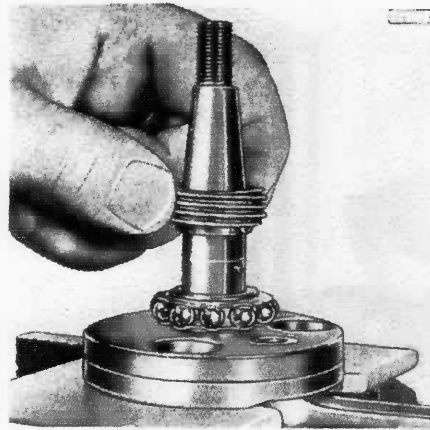

Place special plate 905.0.33.104.1 between crank webs to avoid damage to crankshaft. Use installation sleeve 350.1.70.012.0 to install oil pump drive gear.

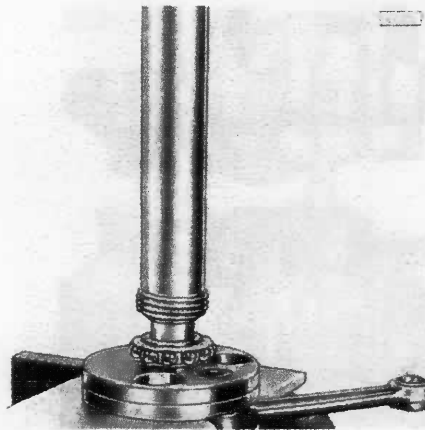

Oil pump drive shaft must be placed in crankcase before installing the guide sleeve.

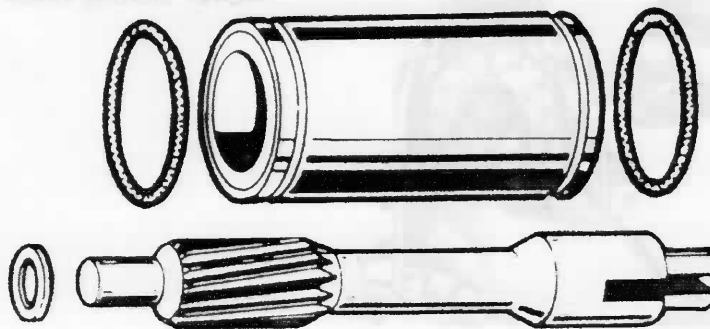

Before installing the drive shaft guide, replace the two (2) "O" rings on guide sleeve. For easier installation lubricate both "O" rings.

ASSEMBLE ENGINE - 2 SPEED

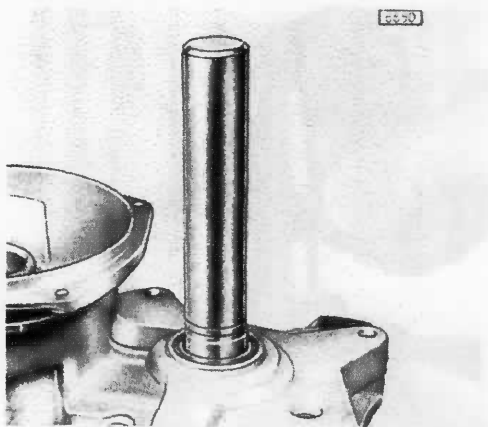

Press sleeve with the tool 905.6.33.111.2 on drive shaft.

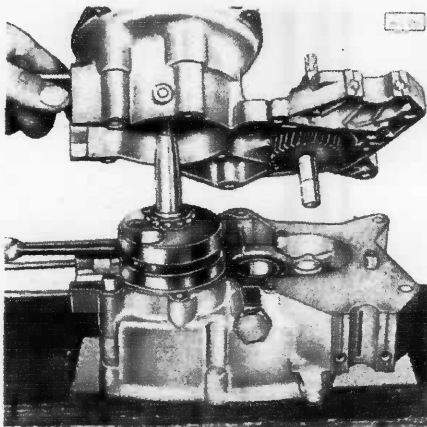

While rotating crankshaft place both crankcase halves together.



Do not force halves together.

Replace screws and torque to 6 ft/lb (8 Nm).

Again rotate crankshaft to ensure correct installation.

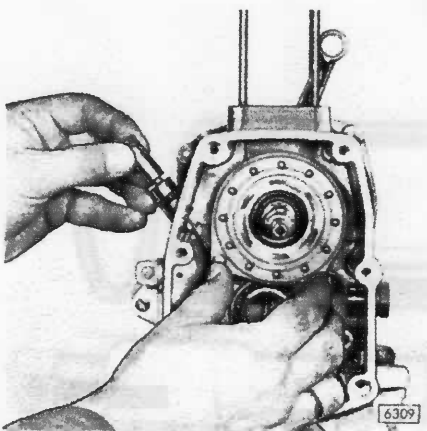

Place engine into engine holder 905.6.36.108.0. Replace engaging plate into housing and screw the adjusting nut into the starter cable.

NOTE: Starting clutch adjustment will be carried out later.

ASSEMBLE ENGINE - 2 SPEED

Right hand crankcase half:

Install crankshaft seal with the sealing lip facing the clutch side using special tool no. 905.6.33.112.1 in order to prevent obstruction of the main bearing lubricating hole.

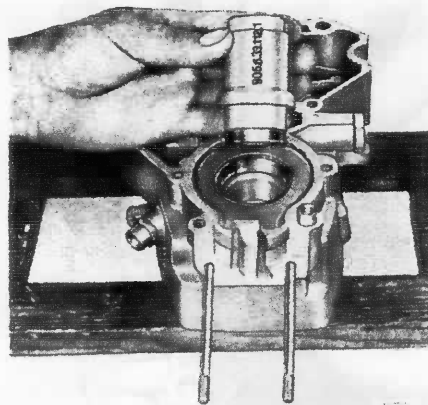

INSTALL CRANKSHAFT

Before installing the clutch side bearing fit a .004in. (0,10 mm) shim.

Press on the clutch side inner bearing race. To install, use special sleeve 905.6.33.111.2 and the special plate 905.0.33.104.1 between the two crankshaft webs. When pressing on the bearing race, the bearing identification marks should be located outboard.

Crankshaft end-float .002 - 006 in. (0,05 - 0,15 mm).

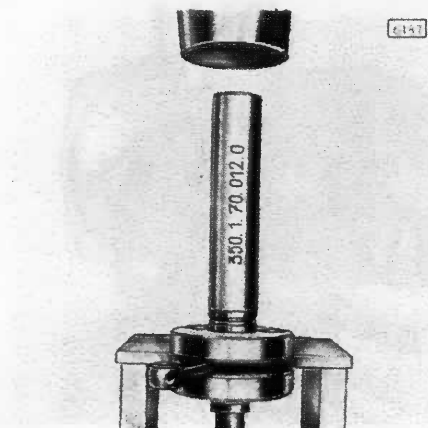

Insert the crankshaft, with bearing pressed into position, in the right crankcase half, and locate a new gasket in position over the hollow dowels. When installing the crankshaft use installation sleeve no. 905.6.31.108.1 to avoid damage to the lips of the seal.

NOTE: It is very important to use a new and genuine gasket, or correct end-float measurements are not obtainable.

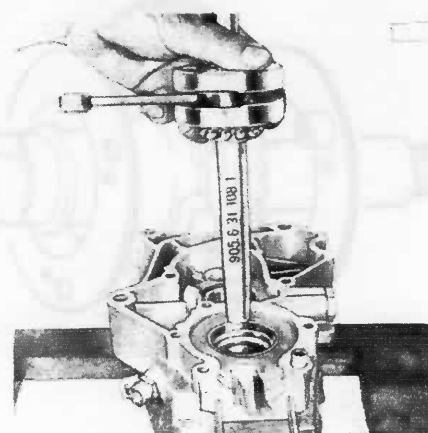

ASSEMBLE ENGINE - 2 SPEED

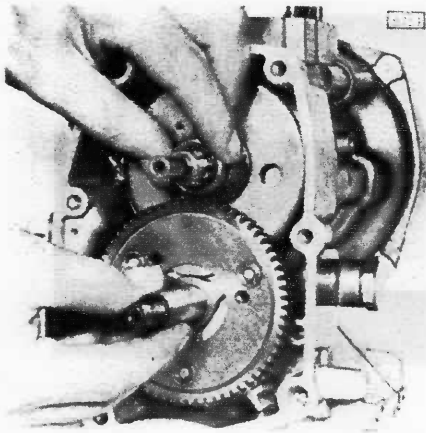

Install second gear driving plate and main shaft in housing.

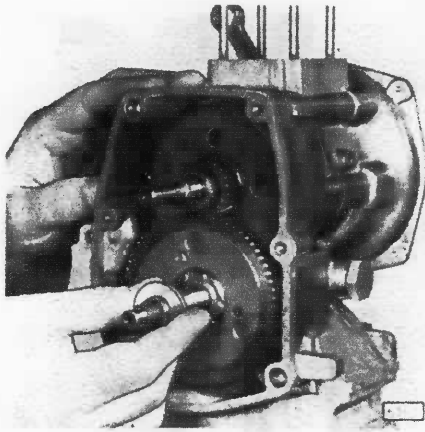

Place thrust washer on main shaft.

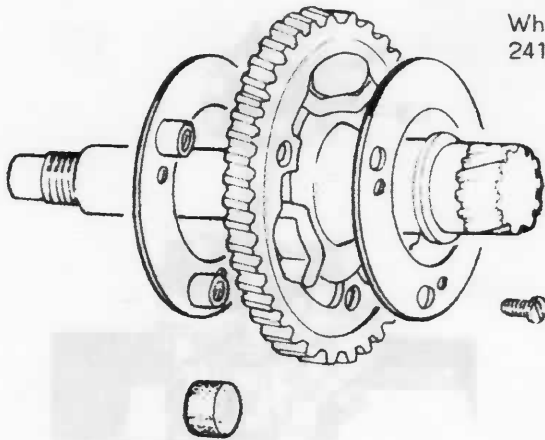

When assembling second speed gear damper, use Loctite 241 on threads and install screws from inside facing outward.

ASSEMBLE ENGINE - 2 SPEED

Install second speed centrifugal clutch, spring out cover plate facing inward.

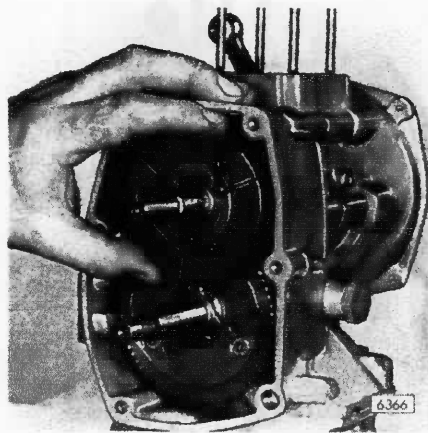

Replace spacer with the cone shaped side facing inward.

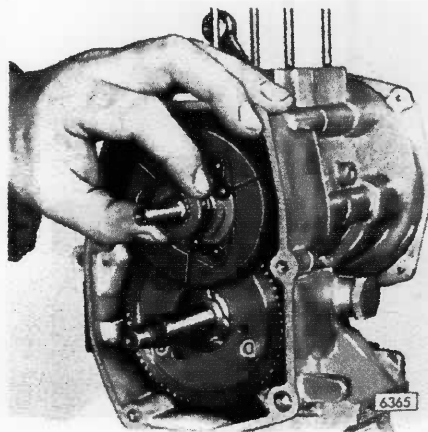

Install first speed centrifugal clutch, spring cover plate facing outward.

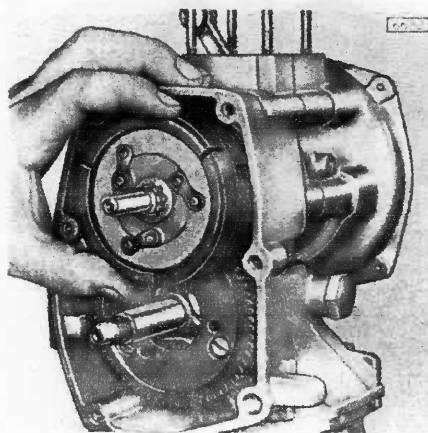

ASSEMBLE ENGINE - 2 SPEED

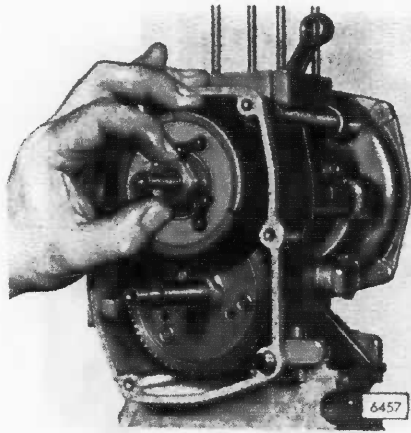

Place new locking tab washer and replace nut.

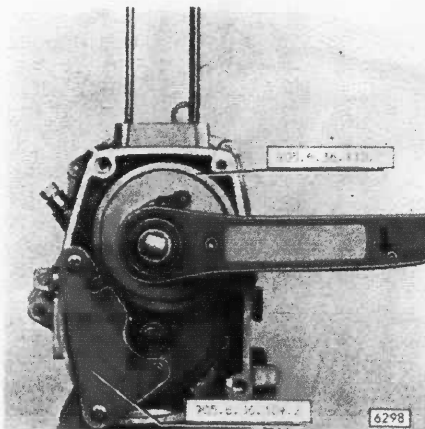

Lock the first speed clutch and second gear main shaft using special tools no. 905.6.36.110.2 and 905.6.36.109.2. Torque nut to 22 - 29 ft/lb (30 - 40 Nm) and secure lock nut with the locking tab washer. Remove clutch locking tool.

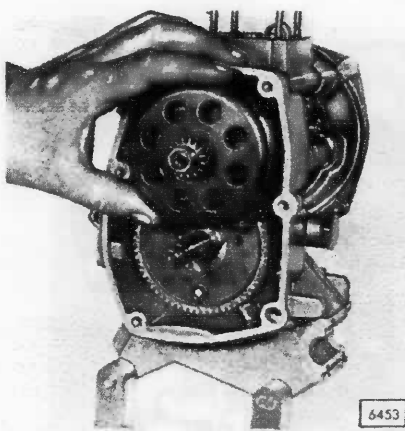

Lubricate bushing on end of crankshaft and install clutch drum.

ASSEMBLE ENGINE - 2 SPEED

Place first speed gear onto main shaft.

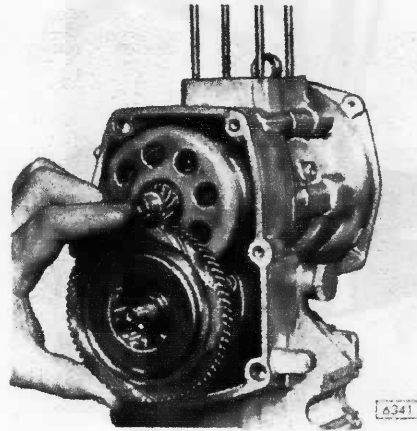

Re-fit special nut (left hand thread) into main shaft and torque to 25-36 ft/lb (35-50 Nm). Remove second speed gear locking tool.

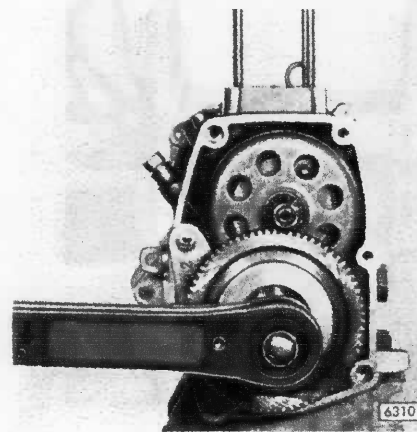

Insert the first speed gear rollers, by pushing springs back and placing rollers in position against the spring tension. Remove engine from engine stand and place on assembly table.

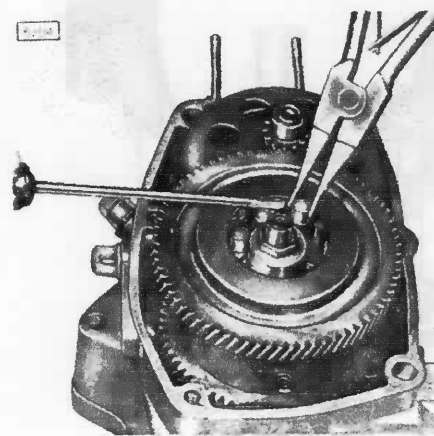
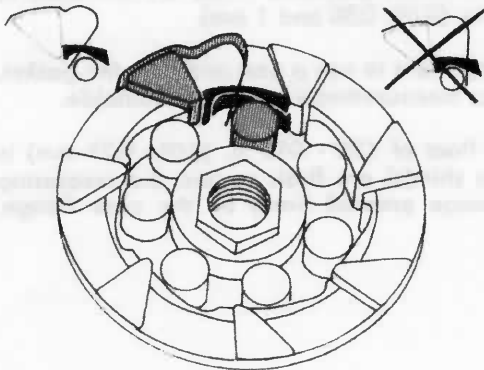

ASSEMBLE ENGINE - 2 SPEED

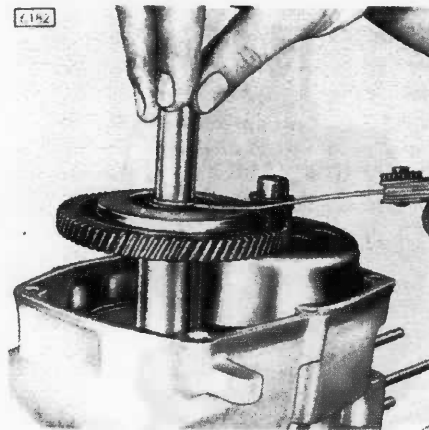

Install roller retainer thrust plate. Ensure that the head of the special nut protrudes through the thrust plate. Now place a thick shim over the end of the main shaft.

While holding down shim measure gap between special nut and shim. This gap must be .002 - .010 in. (0,05 - 0,025 mm). To obtain the correct end-float the thrust plate is available in 6 different thicknesses. Sizes of thrust plates are .165; .173; .181; .189; .197; .205 in. (4,20; 4,40; 4,60; 4,80; 5 and 5,20 mm).

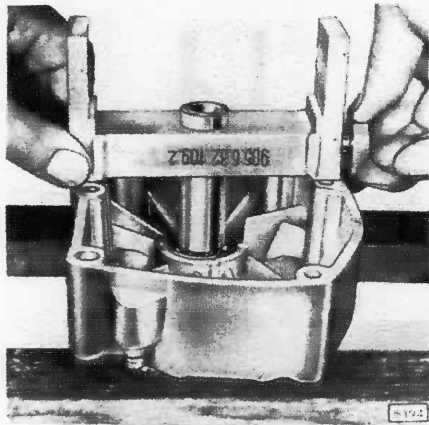

MEASURING MAIN SHAFT AND CLUTCH DRUM END-FLOAT

When installing new bearings in clutch cover, heat cover to appr. 170° F (80° C) and press bearings into place.

A special measuring tool no. 905.6.32.109.0 is used to measure the end-float between the first speed gear main shaft and the clutch cover.

Fit a new gasket to the cover, place measuring device firmly on top of the gasket. Slide down the measuring sleeve to contact the inner surface of the bearing. Hold measuring device firmly against gasket and bearing and lock measuring sleeve in that position.

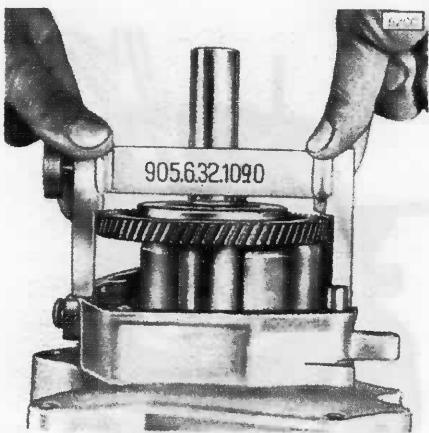

Now invert and place measuring tool over the main shaft. Compensate the gap between measuring sleeve and main shaft with the use of shims provided. Shims are available in .024 .031 and .040 in. (0,60; 0,80 and 1 mm).

NOTE: It is very important to use a new and genuine gasket, or correct end-float measurements are not obtainable.

The specified end-float of .002 - .010 in. (0,05 - 0,25 mm) is obtained when the shim(s) are flush against the measuring sleeve with the gauge pressed firmly on the case flange.

ASSEMBLE ENGINE - 2 SPEED

The same procedure should be used for the shimming of the clutch drum. Shims are available in the size of .024; .031 and .040 in. (0,60; 0,80 and 1 mm). The correct end-float on both shafts is only obtained by using a new gasket. End-float is between .002-.010 in. (0,05-0,25 mm).

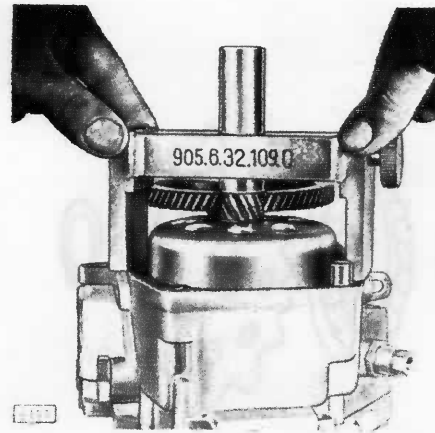

Place engine in special holder 905.6.36.108.0.
When installing new bearings in clutch cover, heat cover to appr. 170° F (80° C) and press bearings into place.
Fit new gasket, install both hollow dowels and fit clutch cover.
Torque screws to 6 ft/lb (8 Nm).

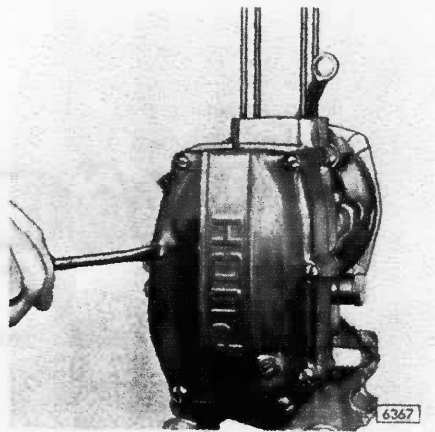

Install engine drive sprocket and secure with a circlip.

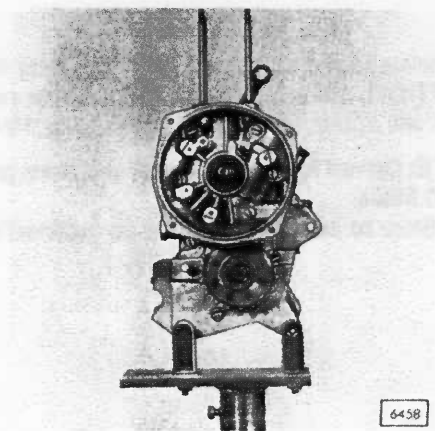

ASSEMBLE ENGINE - 2 SPEED

AUSTOR DAIMLER Series

Install inner circlip, drive sprocket, tappet ring and outer circlip.

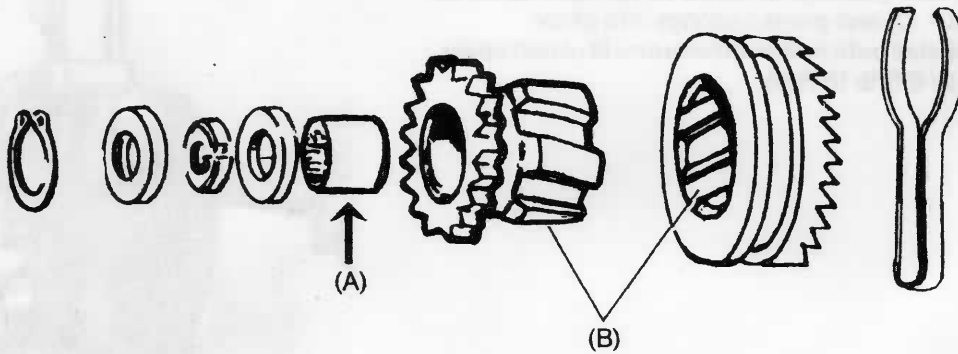
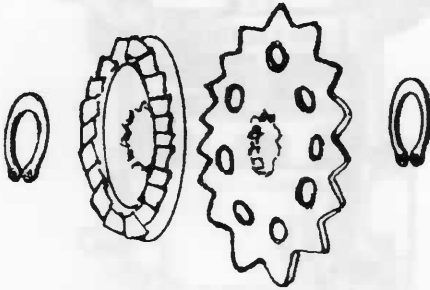

Continue to install all parts of the starter mechanism as illustrated above.

CAUTION: Do not forget to lubricate needle bearing (A) before installation, as damage to the drive shaft will occur. Use Bosch grease (Fd 1V4). Remove gear and lubricate every 3600 miles.

NOTE: Do not lubricate tappet and drive gear (B) with grease. Use only normal engine oil. Lubricate every 1800 Miles.

Continue to assemble engine as outlined on previous pages.

INSTALL ENGINE - 2 SPEED

Install engine in frame and torque mounting bolts to 23 ft/lb (32 Nm). A-D Series (see page 25).

Re-connect electrical wires at junction block (see wiring diagram).

Install drive chain, take care that the tension is correct and the connecting link is properly placed with the closed end pointing in the direction of chain travel.

MAGNUM MK II

Install oil pressure line between manifold and oil pump. Connect oil supply line to oil pump. If an air bubble is visible in the oil supply line between oil tank and oil pump, bleed off air by squeezing the oil supply line.

 **Ensure bleeding procedure is carried out each time hose has been removed from oil tank or oil pump.**

Connect clutch cable to adjusting sleeve, hook-up inner cable to starter lever and adjust free travel (see below).

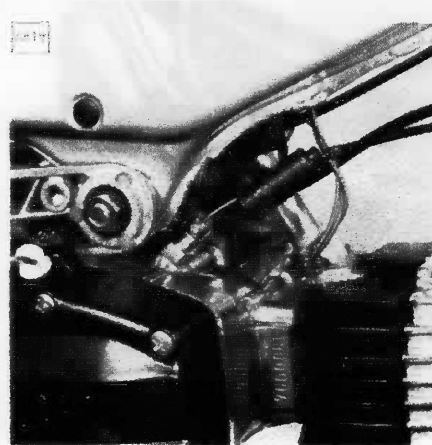
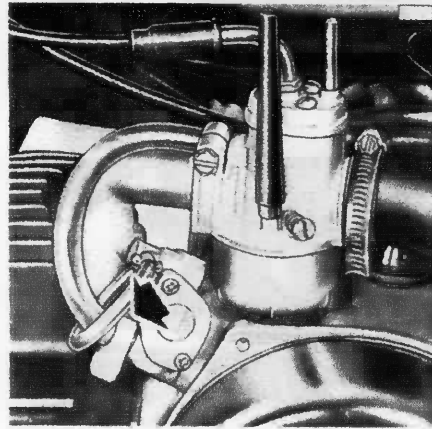

To replace starter cable remove clamp screw on starter lever and remove cable.

Free travel adjustment of starter cable is made on the adjuster, near starter lever (arrow).

Free play should be $\frac{3}{4}$ in. (2 cm) measured at the end of the starter lever play.



INSTALL ENGINE - 2 SPEED

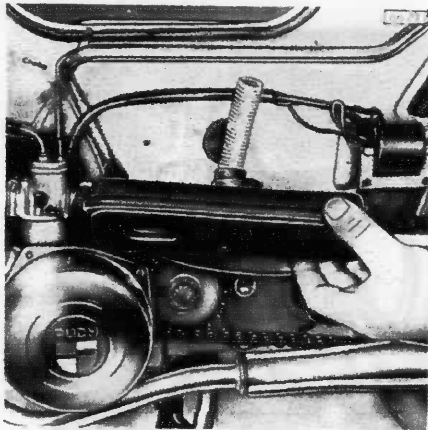

FIT CARBURETOR

Mount carburetor and re-install air filter assembly.



Do not push intake hose too deeply into filter assembly as this could cause air flow restriction.

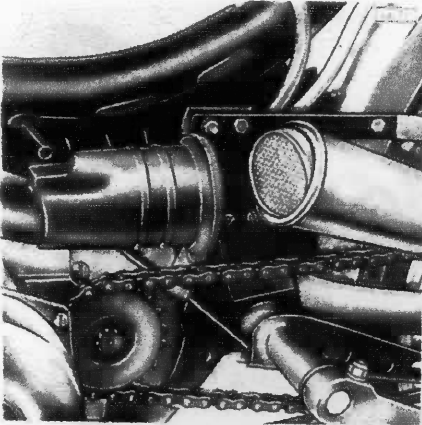

Air filter assembly MAGNUM

Before installing air filter assembly, clean metal filter element with solvent, blow completely dry with compressed air and spray filter element lightly with engine oil (see page 10).

AUSTRO DAIMLER Series: (see page 9 and 10).

Fill transmission at fill plug (arrow) with automatic transmission fluid „Type F“.

NOTE: Do not overfill transmission.

Oil capacity:

2 speed automatic 9½fl.oz. (280 cc)

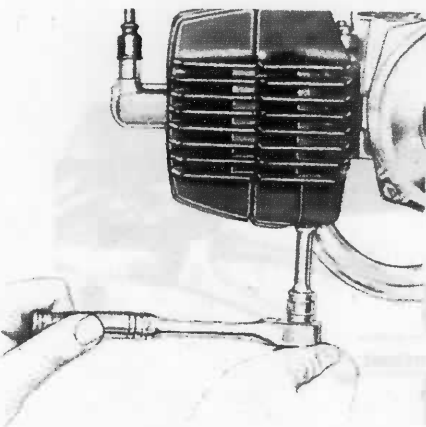

FIT EXHAUST PIPE AND SILENCER

Ensure to use a new gasket between exhaust pipe and cylinder.

NOTE: Do not make any alterations on the exhaust system or poor operating conditions may result.

For throttle cable adjustment see page 12.

OIL TANK - FUEL TANK

Oil tank-MAGNUM MK II

To remove oil tank, remove left side cover, disconnect and block oil supply hose and remove oil tank from its mounting base.



On refitting and connecting oil supply hose ensure there are no air bubbles visible in the oil supply hose.

Fuel tank, MAGNUM

To remove fuel tank, remove the seat mounting nuts and lift seat of frame.

The fuel tank is mounted on rubber pads in front and rear. Turn fuel tap to "Off" position, disconnect fuel cross-over line and the line from the fuel tap. Lift the tank to the rear and remove.

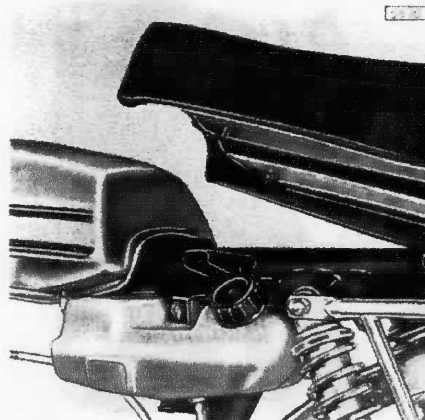

Fuel tank, DART

Remove top cross bar, drain fuel from tank and disconnect fuel hose.

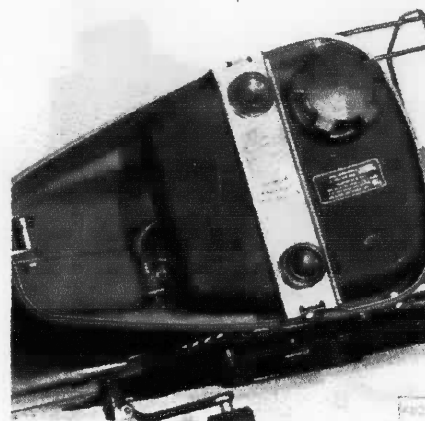

Fuel tank A-D Series

Drain fuel from tank. Remove tail light assembly and base plate retaining screw (1). Use allen wrench to remove both rear tank retaining screws (2).

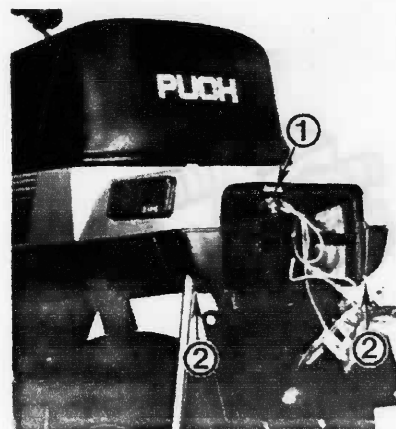

FUEL TANK - FUEL TAP

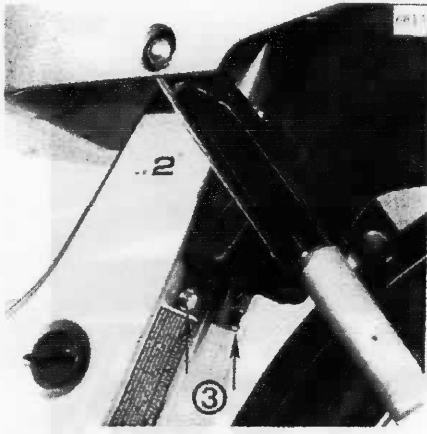

Remove mounting screws (3). Pull fuel tank toward the rear, disconnect fuel hoses and remove fuel tank.

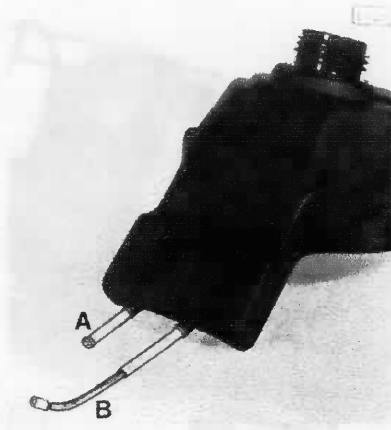

NOTE: When installing the fuel tank, be sure to connect the fuel line which comes from the fuel cock side marked "R" (see below) to the shorter fuel strainer (A) and the other hose to the longer fuel strainer (B)

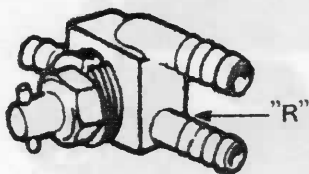

Marked "R" (Reserve)

FRONT FORK - MAXI, DART, COBRA

DISMANTLE FRONT FORK

Disconnect front brake cable and speedo drive cable. Un-screw both axle nuts and remove front wheel. Remove front fender and headlamp. Remove the two (2) top bridge hexagonal bolts.

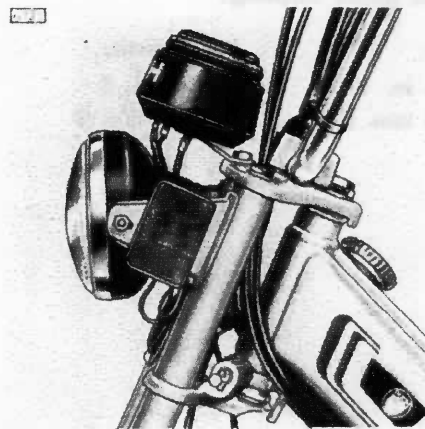

Pull both sliding tubes down and out of fork tubes.

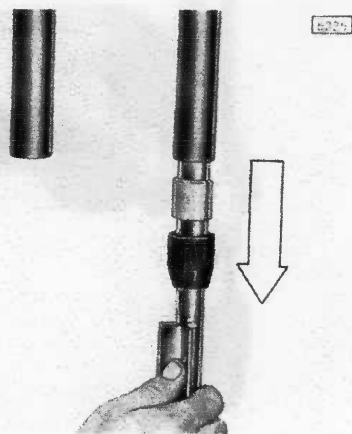

Remove steering stem nut, lift off top bridge and handlebar assembly and place over frame. Remove lower steering stem nut and pull down bottom bridge assembly.

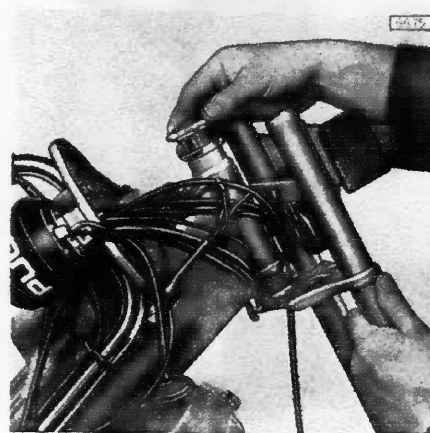

Knock out steering head bearing cups and install with special tool 905.6.34.501.0.

FRONT FORK - MAXI, DART, COBRA

Plastic guide bushing:

New:

1,06 in. ϕ
26,95 mm ϕ

Wear limit:

1,04 in. ϕ
26,5 mm ϕ

SPRING DIMENSIONS:

Wire Diameter .118 in. (3 mm)

Spring length

New: 7,24 in. (184 mm)

Wear limit: 6,90 in. (175 mm)

1.5

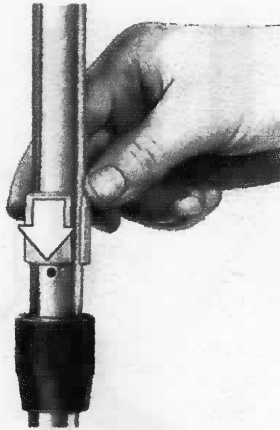

ASSEMBLING FRONT FORK

Place dust covers over sliding tube.
Fit both plastic guide bushings. Place locating tab on inside of bushing in position on lower sliding tube.

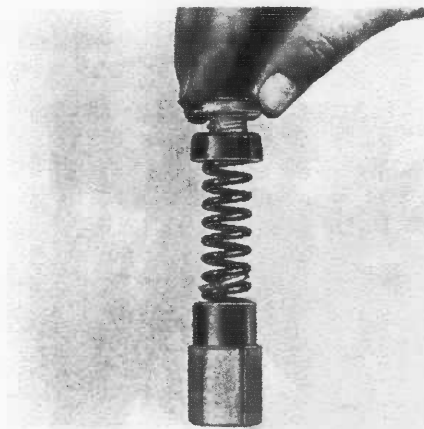

Insert spring in lower tube and rubber stop inside spring.
Place damper rubber over spring end and screw on top threaded coupling.

FRONT FORK - MAXI, DART, COBRA

Grease both bearing cones and cups and install bottom bridge.

NOTE: Do not tighten lower nut, front fork must turn easy but no play noticeable.
Install spacer on steering head shaft.

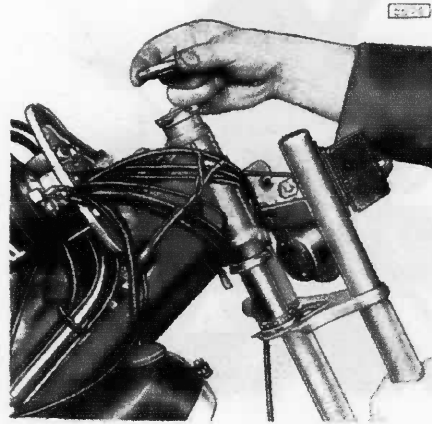

Replace top fork bridge, torque steering head nut to 30 ft/lb (41 Nm). Recheck steering head bearing for clearance.



Grease guide bushings and insert in lower fork tubes.

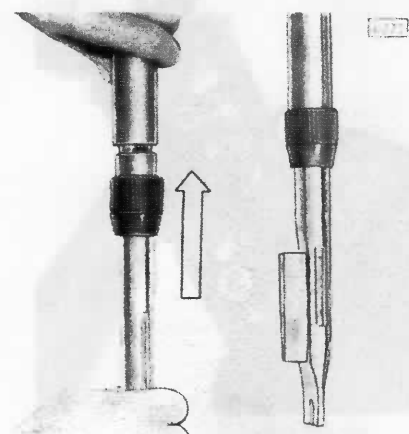

FRONT FORK - MAXI, DART, COBRA



Torque bridge bolts to 11 ft/lb (15 Nm).

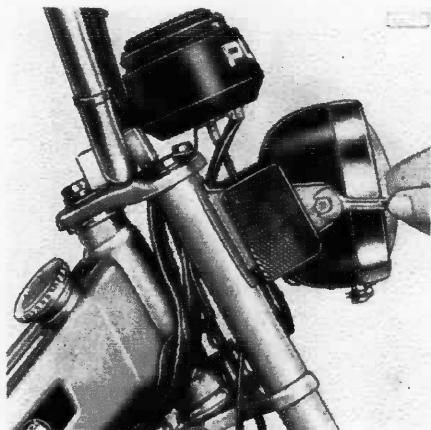

Install headlamp, front fender and front wheel.
Adjust headlamp.

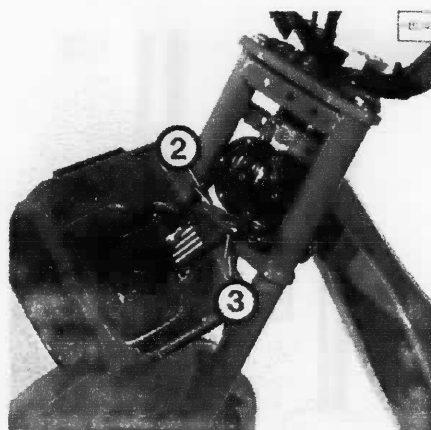

When remounting the cover, make sure that the pinion of the covering (2) engages in the bore provided (3) at the lower fork bridge.

FRONT FORK - MAGNUM II, XK

DISMANTLING

FRONT FORK, MAGNUM II (also MAGNUM XK)

After removing the front wheel, fender handlebar, headlamp and speedometer, remove the top bridge bolts. Remove both sliding tubes from fork tubes and inspect for wear. If lower or upper fork tubes are worn or bent, replace as a unit.

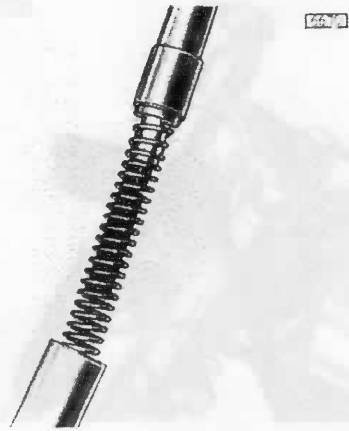

To replace spring or rubber stop inside spring, unscrew spring from coupling.

Spring length: New 7.68 in. (195 mm)
 Wear limit 7.28 in. (185 mm)
Rubber stop length: 4.72 in. (120 mm)
Wire diameter: .14 in. (3,5 mm)

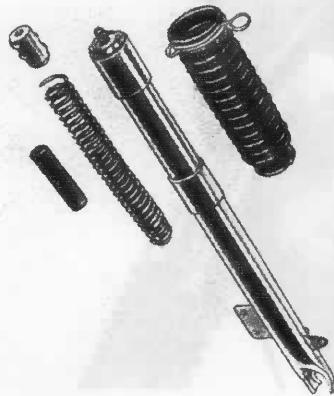

ASSEMBLING

Assemble the front fork in the reversed order to dismantling. Lubricate lower sliding tubes with grease prior assembling. Torque upper bridge bolts to 11 ft/lb (15 Nm).



FRONT FORK - MAGNUM MK II

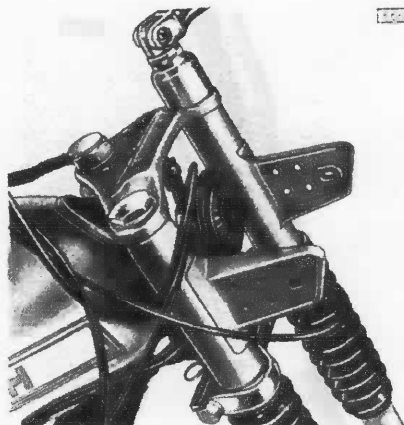

DISMANTLING

HYDRAULIC FRONT FORK MAGNUM MK II

After removing cockpit, headlamp and handlebar unscrew the two (2) upper bridge sealing plugs and washers.

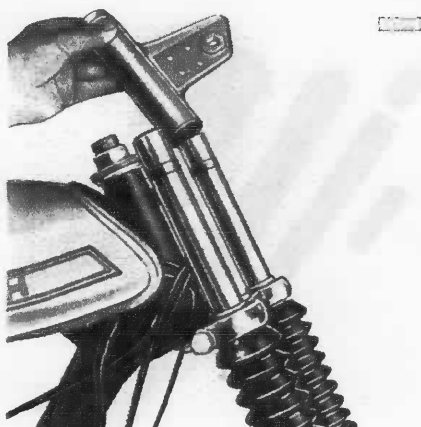

Further removing the two (2) upper tube clamp bolts (arrow). Remove the top fork bridge, both headlamp carriers and sealing bands.



Pull down both tube assemblies.

NOTE: If tubes are very tight in lower fork bridge, replace sealing plugs in inner tube assemblies and drive out tube assemblies using a rubber or plastic hammer.

NOTE: Before proceeding further, drain off oil from tubes.

FRONT FORK - MAGNUM MK II

Place lower tube in a vise, using soft jaws to prevent damage to lower tube, and remove nut to separate the upper and lower tube assemblies.

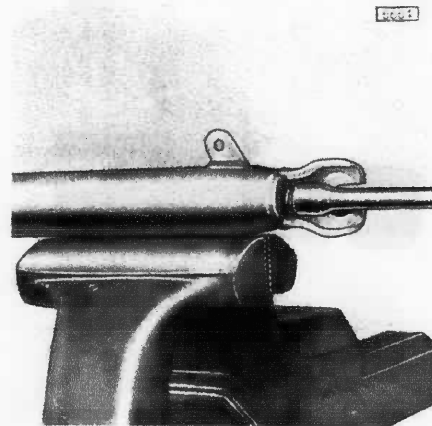

Inspect all parts for wear and replace if required.

NOTE: Always replace lower fiber washer, "O" ring, guide ring on piston and seals in sliding tubes to ensure perfect sealing of hydraulic fork.

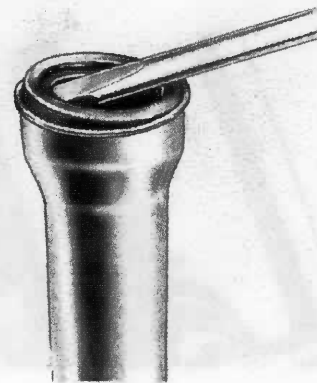

ASSEMBLING

Install seals in lower sliding tubes.

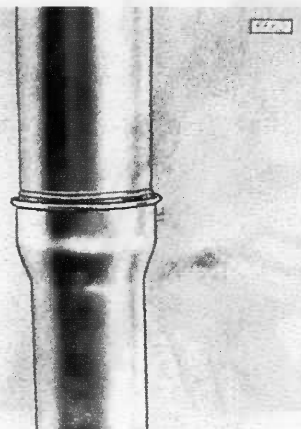

FRONT FORK - MAGNUM MK II

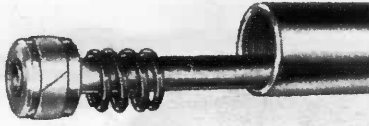

Install seals in lower sliding tubes.

Install new wear ring on piston, fit damper spring (short) over piston rod and insert piston assembly in fork tube, so that the threaded end is sticking thru lower part of tube. Place damper spring (long) over piston rod and small "O" ring on bolt shaft. Assemble upper and lower fork tubes. Before installing nut on end of piston rod, place a new fiber washer over rod end.

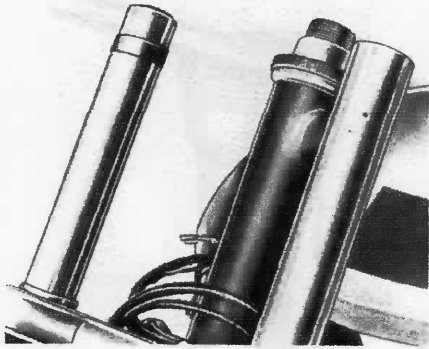

Place rubber bellows over tube assemblies and insert tubes in lower fork bridge.

NOTE: Do not clamp tubes in lower bridge till top bridge is installed. Place rubber sealing bands (p.n. 321.1.30.859.1) over upper tube breather holes.

NOTE: These rubber sealing bands prevent the drainage of oil from fork when moped is layed over on its side.

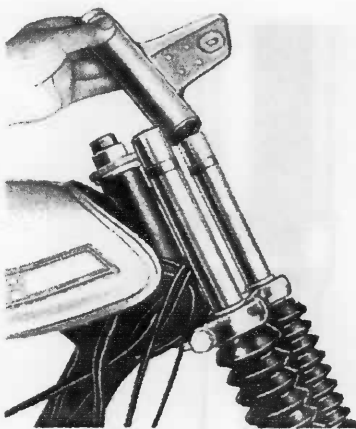

Place both headlamp carries over upper tubes, ensuring the rubber guide rings are positioned inside carrier tubes.

FRONT FORK - MAGNUM MK II

Replace top fork bridge and align with upper fork tubes.

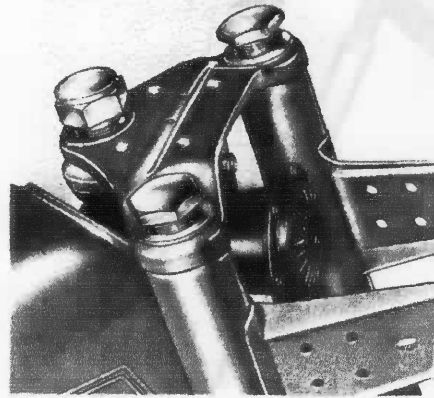

Fill both tubes with oil.

Quantity: 4 oz. (120 cc) per fork tube
Quality: SAE 20-30 motor oil
Spring length: New 16.69 in. (424 mm)
 Wear limit 16.29 in. (414 mm)
Wire diameter: .14 in. (3,5 mm)

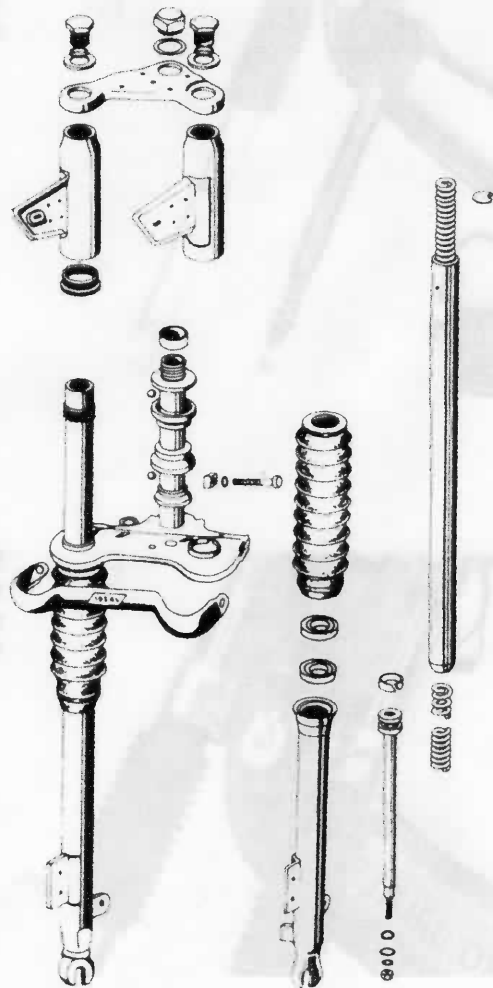

Replace both top sealing plugs with washers. Ensure to replace both "O" rings for perfect sealing. Torque both plugs and steering head nut to 20 ft/lb (27 Nm). Retighten lower fork bridge clamp screws to 40 ft/lb (54 Nm).

FRONT FORK - AUSTRO DAIMLER

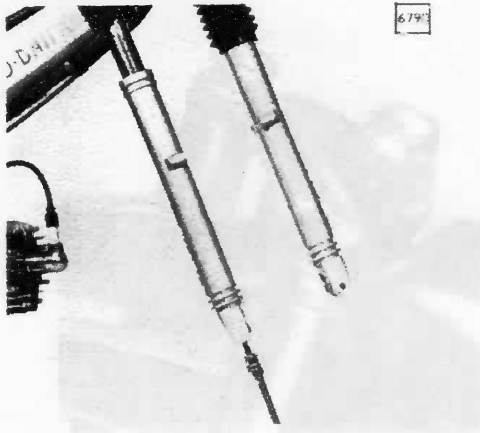

6791

DISMANTLING

(Lower sliding tube)

After removing the front wheel and front fender, unscrew the sliding tube retaining bolt (use a 6 mm allen socket), push up the rubber cover and pull down the lower fork tube.

To remove the seal in the lower tube, use a screw driver and pry out seal. Before installing the new tube, apply grease to the inside of the tube.

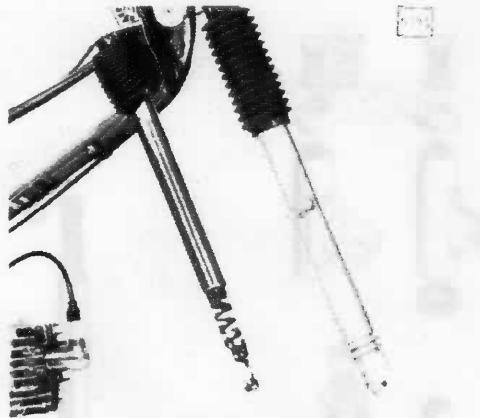

6792

To remove upper sliding tube, remove head light assembly and disconnect all electrical wires.

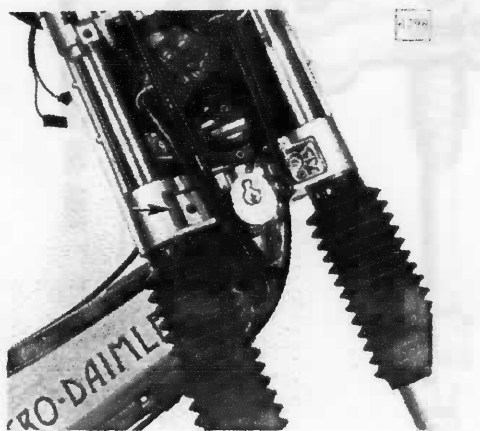

6793

Remove locating sleeve clamping plate.

NOTE: When installing the clamping plate, ensure that the raised part on the clamping plate will fit under the edging of the locating sleeve (see arrow).

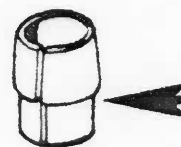

FRONT FORK - AUSTRO DAIMLER

Unscrew upper tube retaining bolt.



To remove tube locating sleeve, carefully twist sleeve with multi-grup, remove sleeve and upper sliding tube.

NOTE: When installing the locating sleeve, slightly tighten upper tube retaining bolt first (see above foto). Than push locating sleeve into position and secure with clamping plate.



Inspect all parts and replace if parts are worn or damaged.

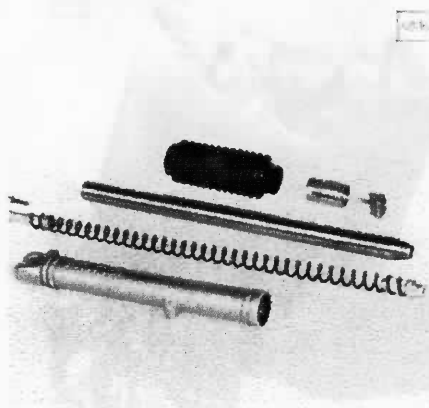

FRONT FORK - AUSTRO DAIMLER

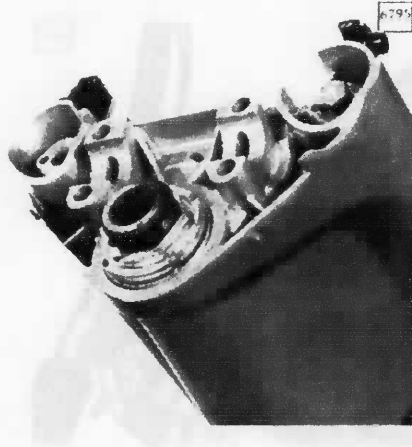

Remove circlip, lock nut and washer.

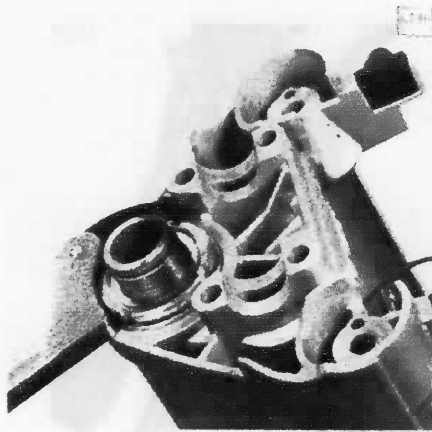

Remove fork head adjusting nut, using special tool 905.1.15.102.0.

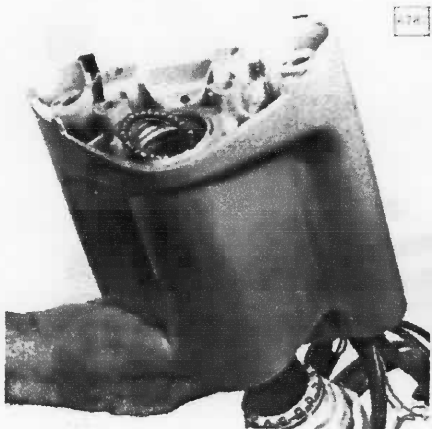

Lift off fork head.

To remove bearing cups, use a drift and knock out bearing cups.

To install bearing cups, use special tool 905.6.33.301.1 and press cups into position.

Grease steering head bearing before installing steering head.

FRONT FORK - AUSTRO DAIMLER

Install retainer nut and adjust steering head with special tool
905.1.15.102.0

CAUTION: Do not overtighten retainer nut. Fit washer and
lock nut and tighten to 18-36 ft/lb (25-50 Nm).
Instal circlip.

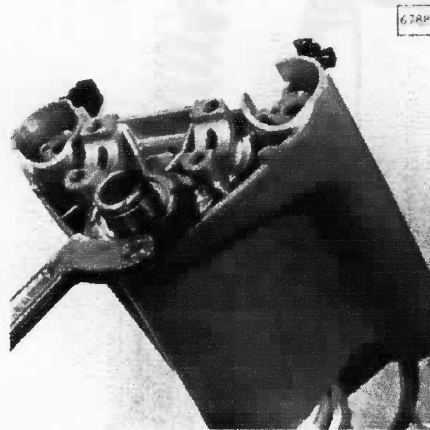

NOTE: The steering head bearings can be replaced without
dismantling the complete front fork.

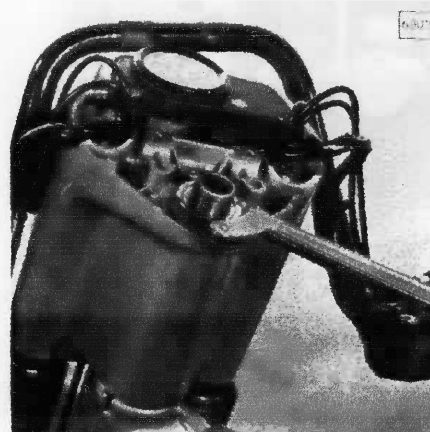

Before installing the front fork, ensure that the sliding tubes
are well greased and the dust boots are not broken.

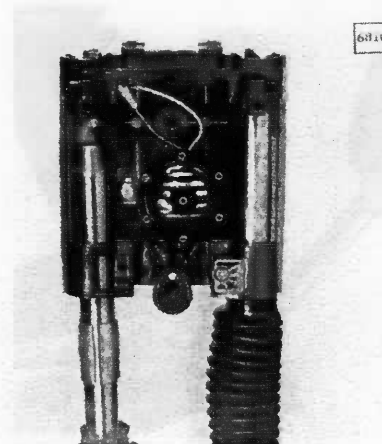

SHOCK ABSORBERS - REAR SWING ARM

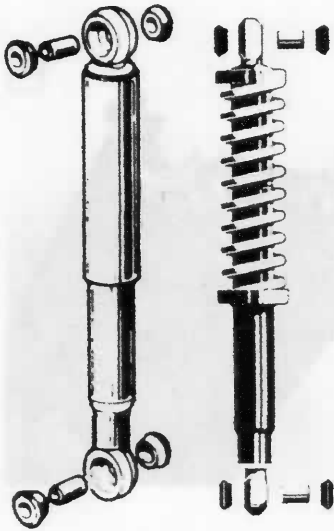

SHOCK ABSORBERS

Shock absorbers are not serviceable, faulty units must be replaced.

Only the upper and lower rubber mountings and bearing bushings are available.

MAGNUM MK II

This shock absorber is a true hydraulic unit but not serviceable, if faulty, replace as a unit.

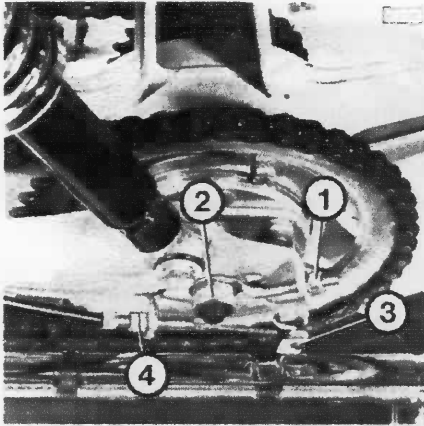

REAR SWING ARM

Remove engine according to repair manual.

Remove rear axle nuts (2), loosen chain tensioners (1), rear brake cable adjustment (4), disconnect cable from backing plate and actuating lever (3) remove rear wheel.

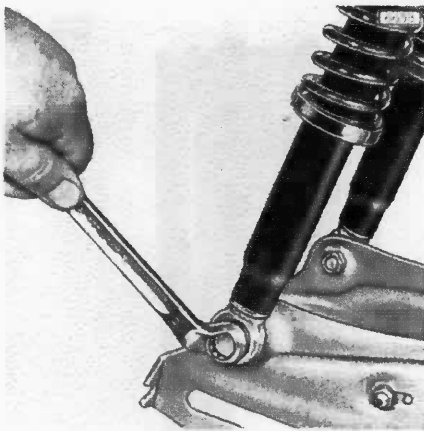

Remove lower shock absorber mounting hardware.

REAR SWING ARM

Remove the four (4) retaining bolts and remove bearing cup, rear fork and rubber bearing.

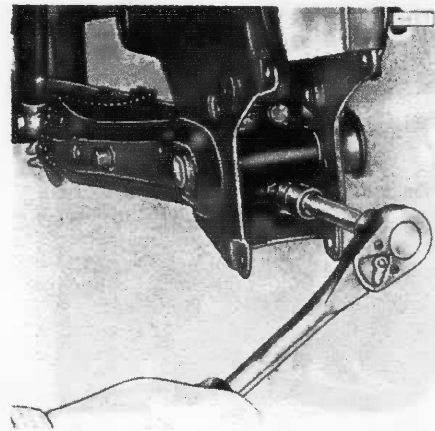

FITTING THE SWING ARM

Proceed in reversed order to dismantling.

NOTE: To prevent excessive pre-stressing (excess wear) of the rubber bearing the four (4) bearing cup bolts should only be torqued after mounting the shock absorbers. Torque bearing cup bolts to 29 ft/lb (40 Nm).

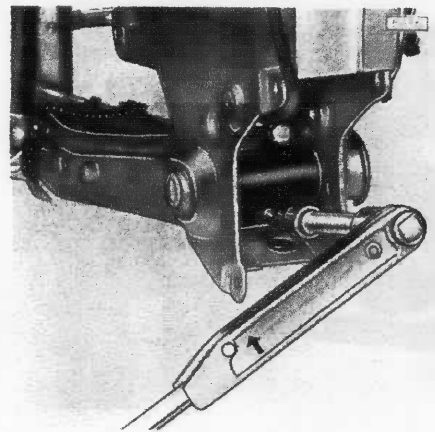

When installing a rear wheel make sure that both wheels are in alignment. Checking and adjusting is easily carried out in any workshop. e.g. The rear wheel is aligned by sighting from the rear (drive side) sprocket up to the engine sprocket. These two sprockets must fall within the same plane. Take two sightings down the chain to avoid error.

NOTE: Do not sight down the chain with the master link on top, as it tends to distort the reading.

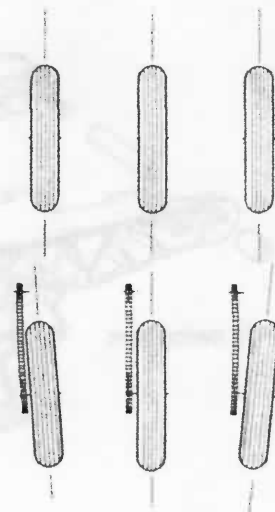

REAR SWING ARM - AUSTRO DAIMLER

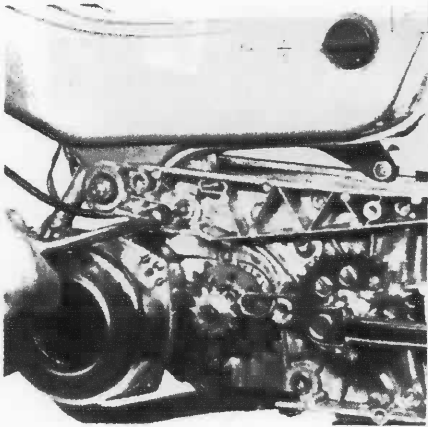

To remove the left or right hand swing arm, just remove the engine mounting bolts, support the engine, remove the pedal crank, kick stand, rear wheel axle and slide-off the swing arm. After re-assembly, tighten engine mounting bolts to 29 ft/lb (40 Nm) and the swing arm bolt to 16-27 ft/lb (21-30 Nm).

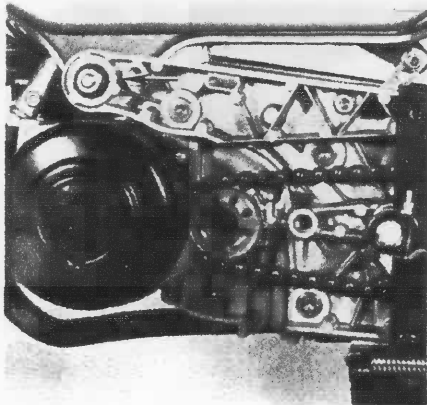

To replace the silent bushes (see arrow) follow the above dismantling procedure. Support the housing and press-out silent bush.

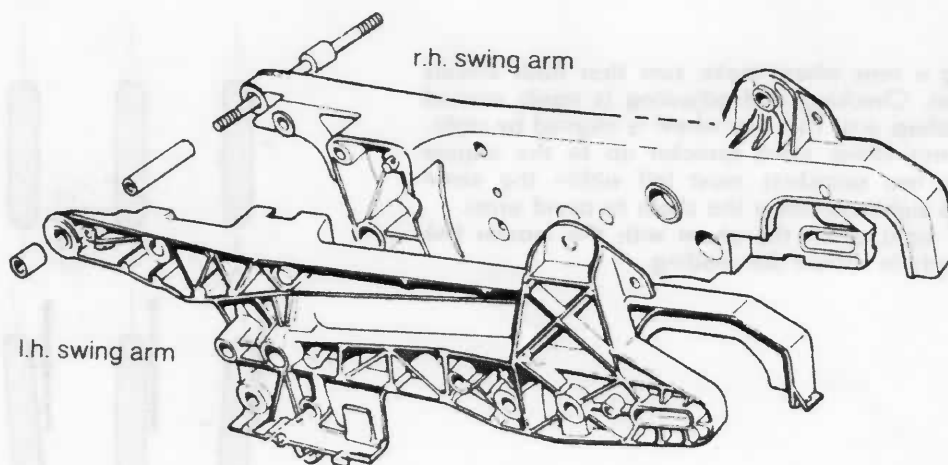

BRAKES

Replacing brake shoes

Pry brake shoes away from backing plate with a screw driver and remove shoes and springs. Roughen brake surfaces of brake drums with emery cloth prior to fitting new shoes. Oiled linings, usually due to over-greasing of brake cam, must be cleaned with gasoline or a similar solvent.

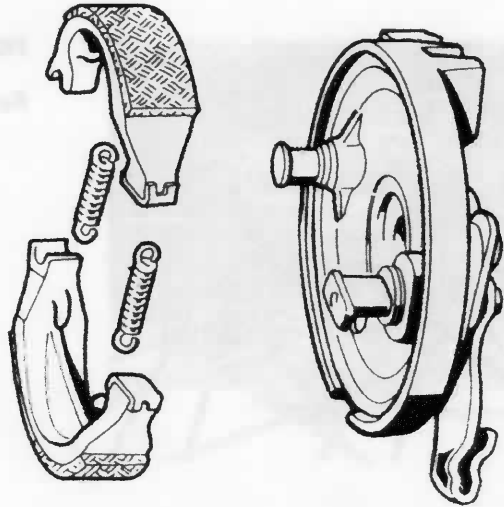

Install return spring with a screw driver after brake shoes have been positioned on backing plate.

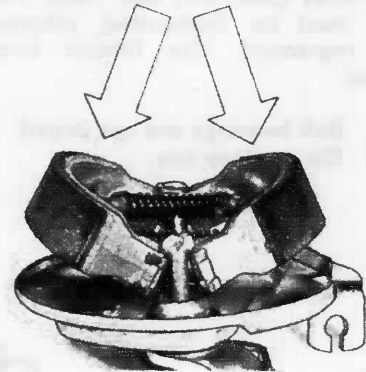

Remove the inspection plugs and insert a flat feeler gauge between the brake drum and the brake lining. The gap should not exceed .047 in (1,2 mm) at either inspection hole. If it does, the brake linings must be replaced. Disconnect cable before measurement is taken.

Bonded linings are used on all brake shoes fitted to our machines. If linings are worn, replace complete shoes.

Brake drum diameter	
New	Wear limit
3,149 in.	3,188 in.
80 mm	81 mm
Diameter of fitted shoes	
New	Wear limit
3,110-3,129 in.	3,039 in.
79-79,5 mm	77,2 mm

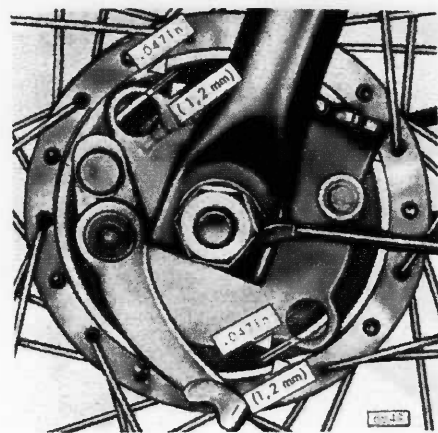

BRAKES - HUBS

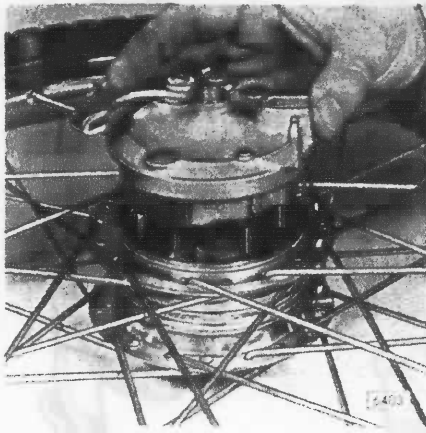

FRONT HUB (LELEU)

Remove lock nut and lift brake assembly out of hub.

If hubs with loose bearings are worn, replace complete sets consisting of bearing cups, cones and balls at the factory. Hubs are greased. The original grease filling is sufficient for approximately 3600 miles (5800 km) use. After this, hubs must be dismantled, cleaned and regreased. Use lithium base grease.

! Ball bearings are not caged. Do not lose any.

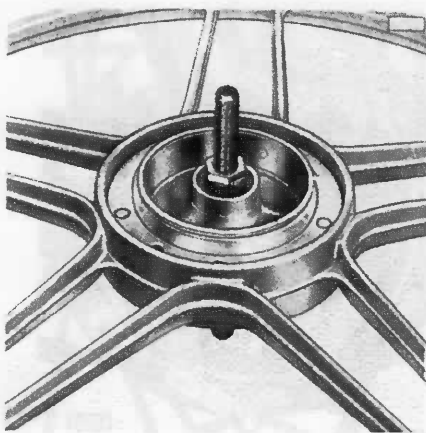
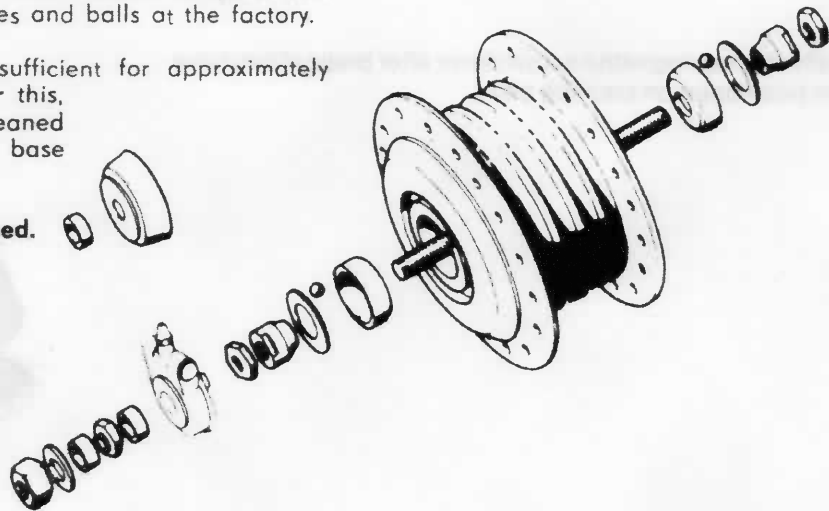

MAG WHEEL

Follow the same procedure as described with the spoke (LE-LEU) hub.

Brake drum diameter

New	Wear limit
3.149 in. (80 mm)	3.188 in (81 mm)

AUSTRO DAIMLER

Front:	New	Wear limit
	3.149 in (80 mm)	3.188 in (81 mm)
Rear:	3.393 in (100 mm)	3.976 in (101 mm)

HUBS

Use special spanner 905.6.35.402.1 to remove bearing cone and remove axle from hub.

Check cones and balls if pitted or damaged and replace if necessary. Old cups may be drifted out, new cups pressed in.

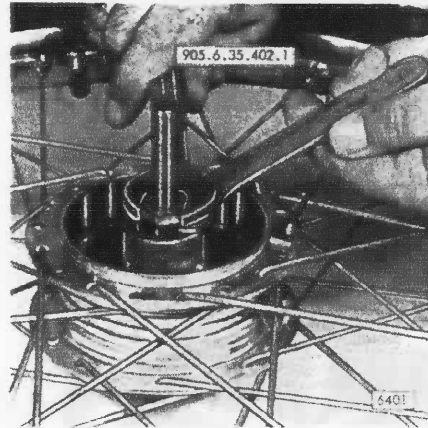

REAR HUB

The rear wheel uses two caged bearing sets, instead of the adjustable wheel bearings used on the front wheel and therefore do not require any adjustments.

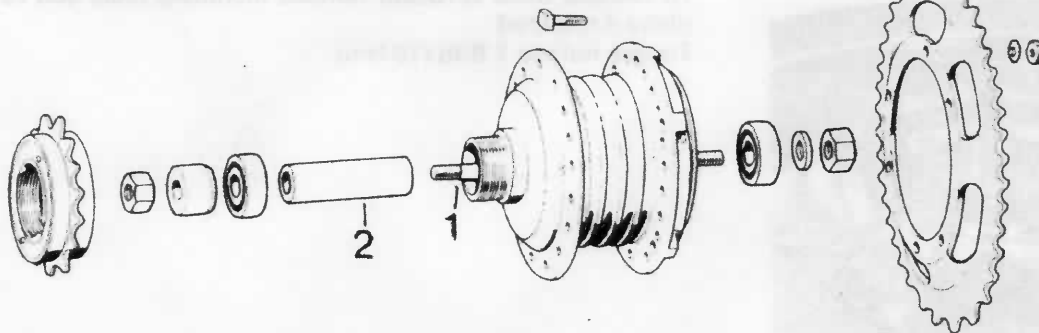

Proceed with bearing removal/installation as follows:

- Remove rear wheel, lift brake backing plate off hub and pull axle out towards brake drum.
- Push bearing spacer (2) to the side to partially clear inner bearing race inside the hub.
- Use punch to knock out one bearing at a time.

Bearing installation steps are:

- Press one bearing into hub insert spacer tube and press in other bearing.
- Insert axle from brake drum side, install brake backing plate and wheel.

NOTE: Ensure that wheel bearings are installed with the covered side facing outward.

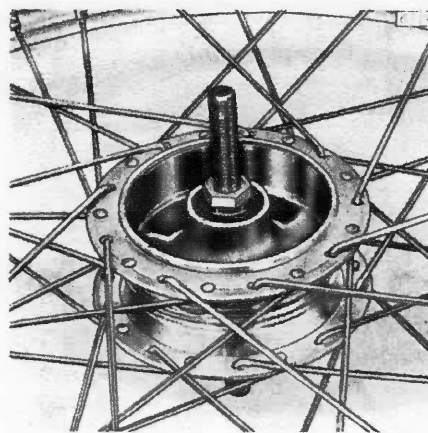

IDLER GEAR - DRIVE SPROCKET

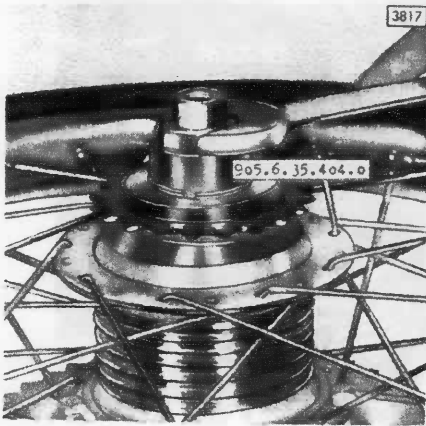

IDLER SPROCKET

It is not necessary to dismantle complete hub to replace idler sprocket. Unscrew complete sprocket with special tool 905.6.35.404.0 and replace if required.

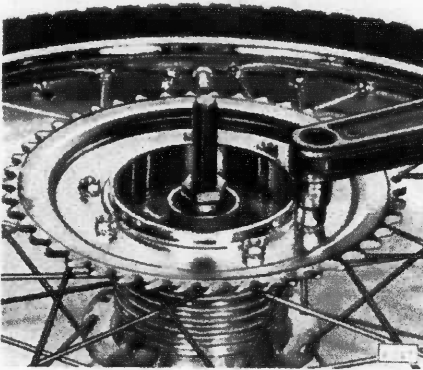

DRIVE SPROCKET

To replace drive sprocket remove mounting bolts and replace if required.
Torque nuts to 7 ft/lb (10 Nm).

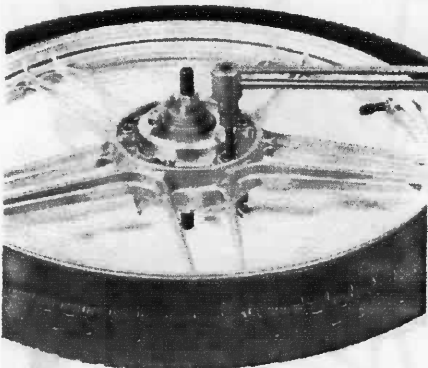

MAG WHEELS WITH REMOVABLE HUBS

When installing new rim or hub, retaining screws must be secured with loctite.
Torque screws to 16-27 ft/lb (21-30 Nm).

TIRE FITTING

TIRE CHANGING SCHEMATIC:

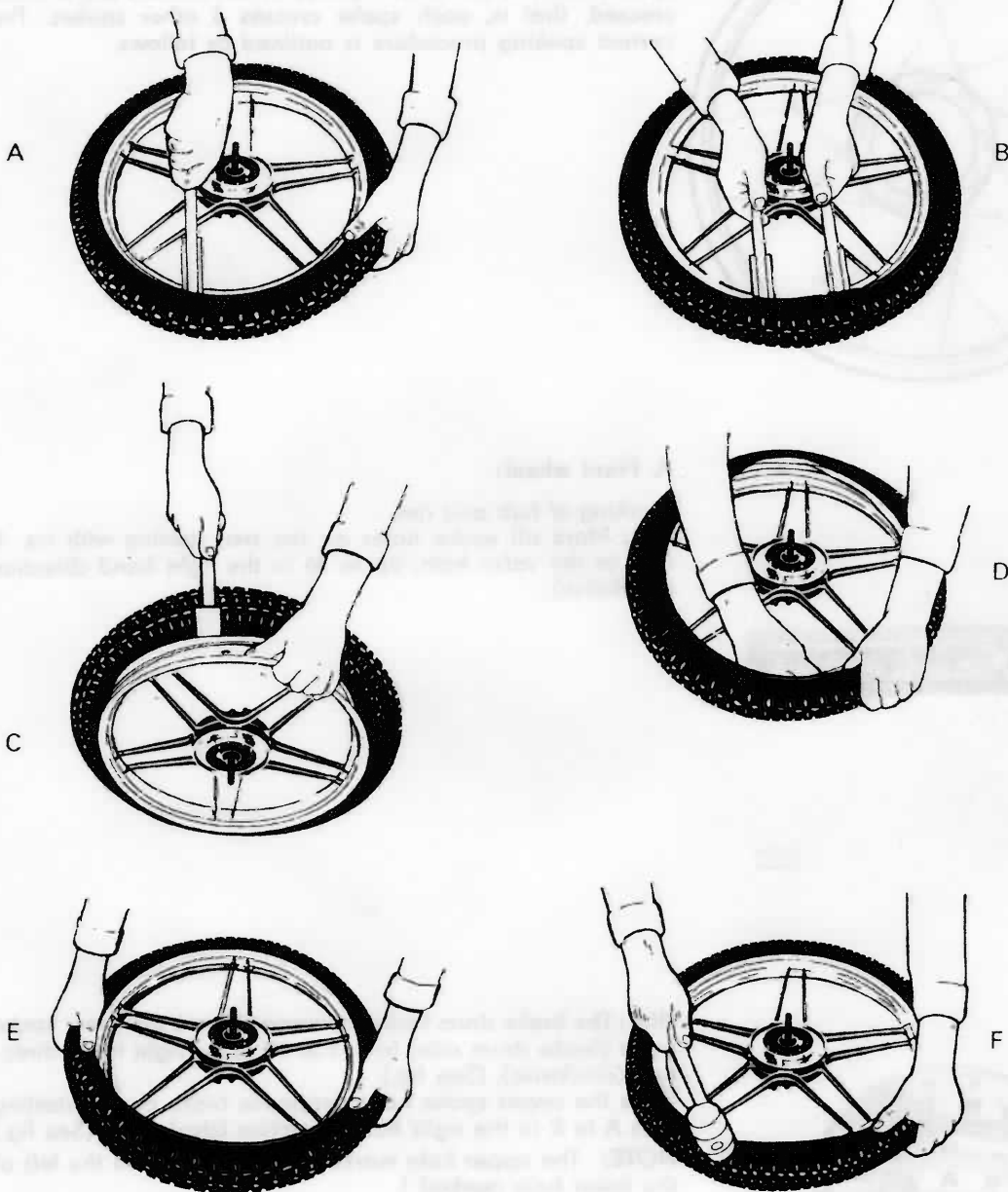

REMOVAL OF TIRE AND TUBE

⚠ It is essential when changing a tire to protect the aluminum rim from damage from the tire lever. Always use a leather or rubber strip between lever and the rim (fig. A, B and C).

SPOKING WHEEL

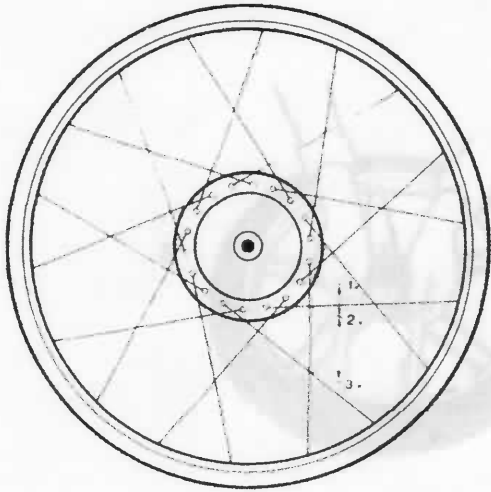

SPOKING WHEELS

Respoking requires the knowledge of correct sequence of the spokes in hubs and rims. Spokes of our models are 3 times crossed, that is, each spoke crosses 3 other spokes. The correct spoking procedure is outlined as follows.

A. Front wheel:

Marking of hub and rim.

Rim: Mark all spoke holes on the rim, starting with no. 1, next to the valve hole, up to 36 in the right hand direction (clockwise).

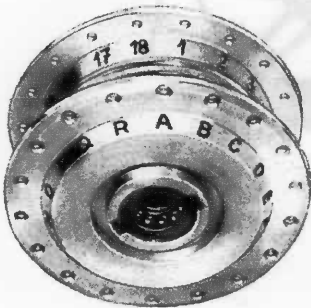

Hub: The brake drum facing downward, mark the lower spoke holes (brake drum side) from 1 to 18 in the right hand direction (clockwise). (See fig.).

Mark the upper spoke holes (opposite brake drum), starting with A to R in the right hand direction (clockwise). (See fig.)

NOTE: The upper hole marked A must be just to the left of the lower hole marked 1.

SPOKING WHEEL

Installing spokes into hub

With the brake drum side again facing downward, install the first spoke into the hole marked 1 (lower hub flange) from the top down.

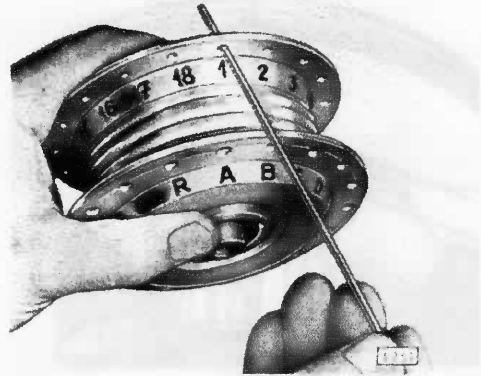

The second spoke is installed into hole marked 2 on the brake drum side of the hub from the bottom up. Continue to install all spokes on brake drum side with the next spoke into hole number 3 from top down, the next into hole 4 from the bottom up. Continue this sequence till all spokes are installed on the brake drum side.

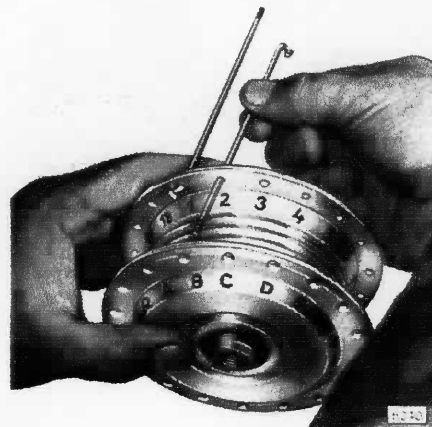

With the brake drum side, the hub still facing downward, install the upper spokes in the spoke holes. Starting on the hole marked A insert the first spoke from the top down (see arrow).

The next spoke from the bottom up into hole marked B. Continue this sequence till all spokes are installed in the upper hub flange.

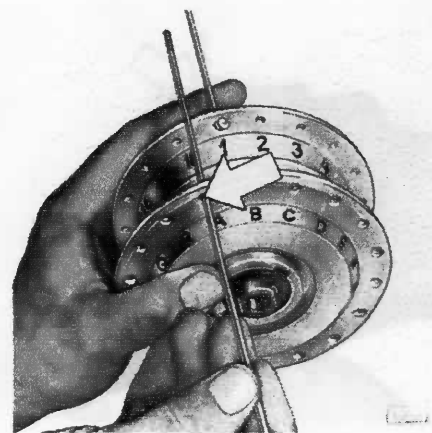

SPOKING WHEEL

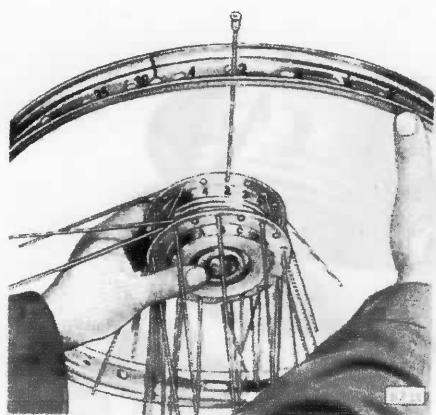

Place the marked rim in the upright position, so that the numbers on the marked rim holes increase to the right (clockwise).

Hold hub with spokes in the center of rim, brake drum facing away, and insert spoke marked 2 on the hub into rim hole marked 2. Place nipple a few turns on spoke thread, then continue to insert spokes in rim the following sequence.

NOTE: It is important that all spokes located on the inside of the hub flanges are installed in the rim first.

Spoke A in rim hole 11	Spoke B in rim hole 1
Spoke 4 in rim hole 6	Spoke 3 in rim hole 16
Spoke C in rim hole 15	Spoke D in rim hole 5
Spoke 6 in rim hole 10	Spoke 5 in rim hole 20
Spoke E in rim hole 19	Spoke F in rim hole 9
Spoke 8 in rim hole 14	Spoke 7 in rim hole 24
Spoke G in rim hole 23	Spoke H in rim hole 13
Spoke 10 in rim hole 18	Spoke 9 in rim hole 28
Spoke I in rim hole 27	Spoke J in rim hole 17
Spoke 12 in rim hole 22	Spoke 11 in rim hole 32
Spoke K in rim hole 31	Spoke L in rim hole 21
Spoke 14 in rim hole 26	Spoke 13 in rim hole 36
Spoke M in rim hole 35	Spoke N in rim hole 25
Spoke 16 in rim hole 30	Spoke 15 in rim hole 4
Spoke O in rim hole 3	Spoke P in rim hole 29
Spoke 18 in rim hole 34	Spoke 17 in rim hole 8
Spoke Q in rim hole 7	Spoke R in rim hole 33
Spoke 1 in rim hole 12	

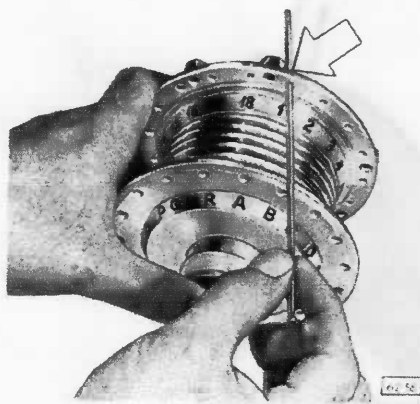

B. Rear wheel:

The spoking of the rear wheel follows the same procedure as outlined for the front wheel except when marking the spoke holes on the lower hub flange (brake drum side facing downward). It is very important to start with number 1 to the right hand side of a drive sprocket mounting hole.

See arrow. If this is not correctly marked the spoking cannot be carried out in the correct manner and there is insufficient space for the drive sprocket mounting bolts.

BALANCING

WHEEL TRUEING

To true a wheel use device such as an old fork having adjustable pins opposite rim ends.

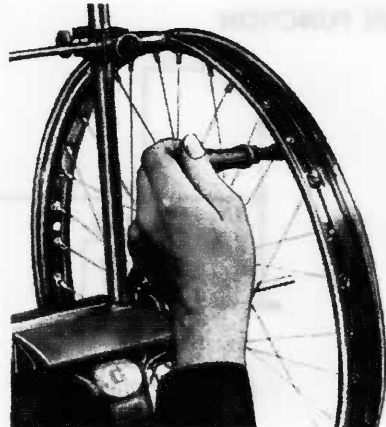

Apart from lining up rim and hub center, trueing a wheel also includes correction of any twist of rim by retensioning certain spokes. If unsuccessful, loosen counter acting spokes a little. A strongly tensioned wheel can often be trued by reducing the tension of the appropriate spoke a little providing the twist is only slight. Always start tensioning and loosening on the part having the biggest twist commencing alternatively to either side. The following spokes are loosened or tightened to a lesser extent. It is usually not possible to true the rim welding.

The special key, no. 905.6.35.401.2 can be used for the trueing of wheels.

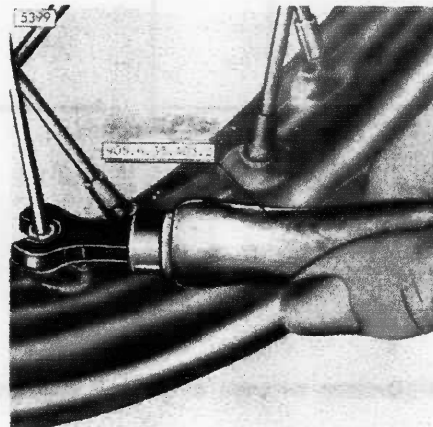

After trueing remove all spoke ends extending beyond nipple heads. Even fractionally protruding spokes will damage the tube. Therefore, any burrs must be filed or ground down.



ELECTRICAL EQUIPMENT

IGNITION FUNCTION

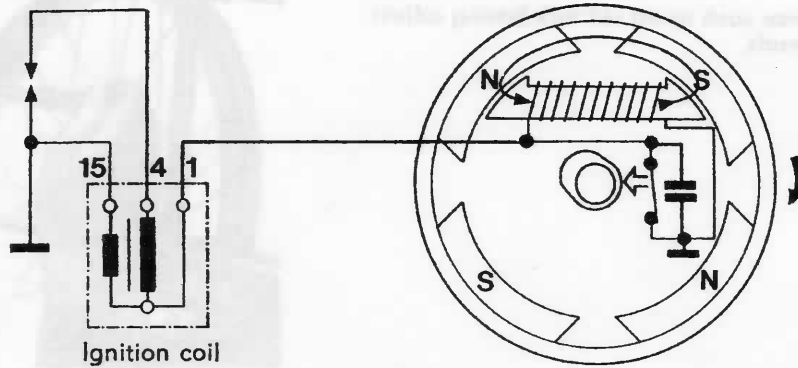

As the flywheel turns, a large number of reverses of magnetic flux is induced in the primary current ignition armature. When the breaker points are closed, as in illustration one, an induced current flows in the ignition armature of the magneto.

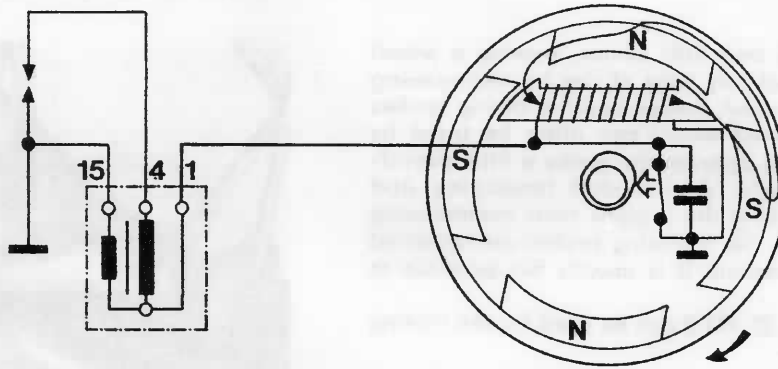

In illustration two the current in the ignition armature is at its greatest value.

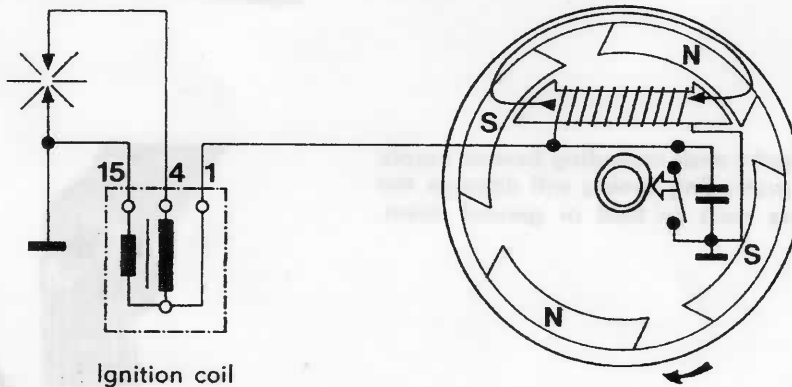

At that point the contact points open and the magnetic flux in the armature core immediately reverses direction, sending current from the magneto armature to the primary side of the external ignition coil. This induces a high voltage in a secondary winding of the ignition coil, which generates a spark at the spark plug electrode.

NOTE: The condenser connected parallel to the contact breaker, prevents the formation of a spark at the breaker contacts.

ELECTRICAL EQUIPMENT

LIGHTING FUNCTION

The magnetic flux, generated by the flywheel, also passes the lighting coil. The flywheel and lighting coil together form an alternating - current generator .i. e. with the flywheel rotating and the circuit closed (bulbs being switched on) alternating current will flow thru the lighting coil windings. The lamp voltage is regulated automatically by the reaction of the alternating current to the magnetic flux of the flywheel and the voltage drop in the lighting coil winding.

This automatic regulation prevents the bulbs from burning out at both low and high engine revolutions. However, the automatic regulation is only effective if the specified load is being adhered to, i. e. if bulbs with specified voltage and capacity are used.

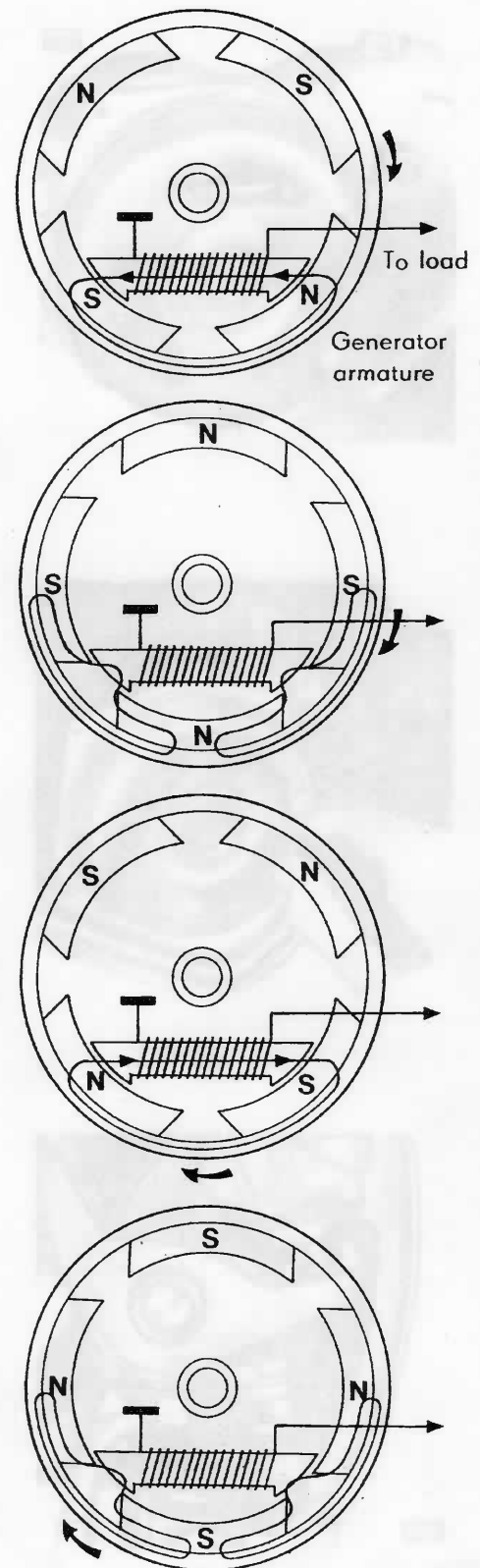

BREAKER POINTS

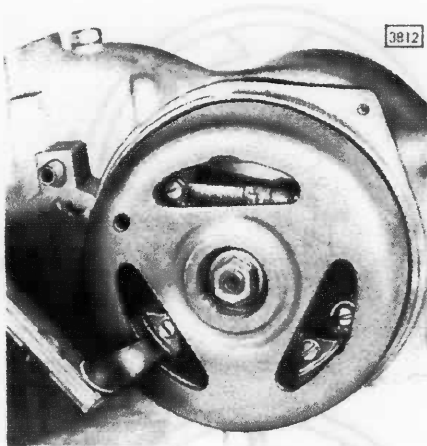

If lighting coil/s has/have been replaced, measure air gap between coil pole shoes and flywheel. Gap should be .016-.024 in. (0,40-0,60 mm). If gap is incorrect, loosen coil mounting screws and adjust as necessary.

! Always check and adjust ignition timing if flywheel has been removed.

Coil resistances in ohms:

Tail lamp	6,7
Stop lamp	1,16
Head lamp	0,23

Ignition coil:

Primary	2
Secondary	5,4

Adjusting breaker points

Rotate flywheel until fully opened point gap is visible thru flywheel port. Loosen fixing screw and adjust point gap to
.014 - .018 in. (0,35 - 0,45 mm) 1-speed engine
.016 - .020 in. (0,40 - 0,50 mm) 2-speed engine

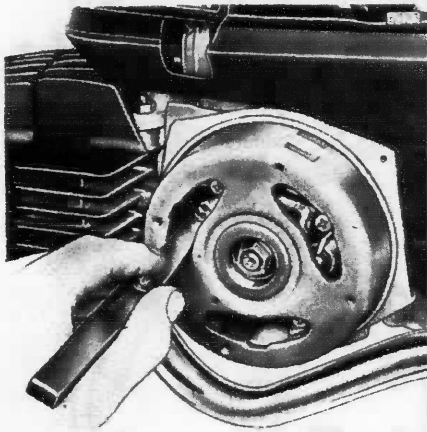

Replacing the breaker points

As already mentioned, points must be replaced if

- They are burned or worn
- Fiber block is worn or loose
- Bacalite bush is worn or loose
- Spring is loose
- Fixed contact or moving contact are bent.

Unscrew cable at the breaker and remove fixing screw. Replace point set.

When fitting new point be sure the contact surfaces are free from grease or oil.

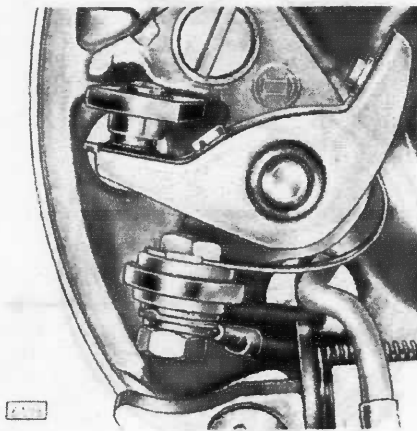

IGNITION TIMING

ENGINE ROTATION

1 speed:

Engine rotation and ignition timing marks on flywheel and crankcase. Engine rotates to the right (clockwise).

2 speed:

Engine rotation and ignition timing marks on flywheel and crankcase. Engine rotates to the left (counter-clockwise).

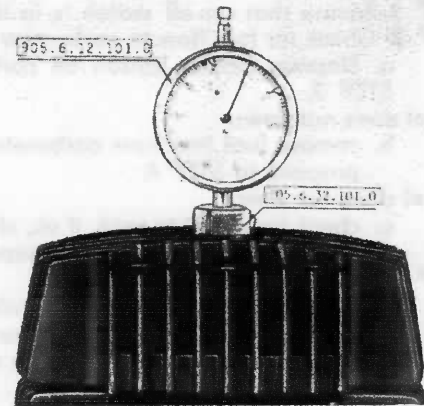

IGNITION TIMING

The engine output depends on correct ignition timing. Too far advanced ignition causes the engine to knock and too far retarded ignition reduces output. In both cases the engine overheats. Checking and adjusting the ignition:

Necessary for proper adjustment:

- 1 Dial indicator holder part no. 905.6.32.101.0
- 1 Dial indicator part no. 905.6.12.101.0
- 1 Puch low scale Ohmmeter 905.6.28.601.0

- a) Remove spark plug
- b) Screw adaptor with dial indicator into plug hole
- c) Connect one cable of Ohmmeter to the blue wire and the other to ground.

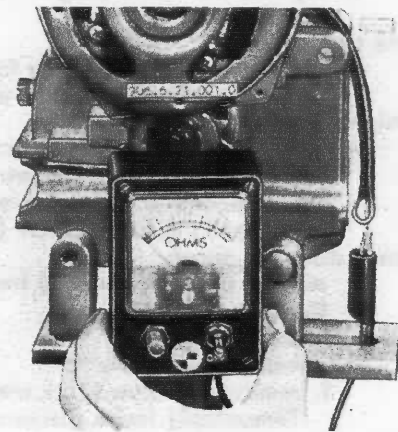

Turn flywheel to find TDC of piston travel and zero gauge. Turn flywheel opposite normal rotational direction (opposite arrow on flywheel)

- 1-speed .032 – .047 in. (0.80 – 1.20 mm)
- 2-speed .051 – .067 in. (1.30 – 1.70 mm)

A needle movement of the Ohmmeter should indicate the points are opening within this tolerance. If the tolerance is not achieved the timing is incorrect.

Re-check breaker point gap or re-adjust till the correct ignition timing is achieved, providing the base plate assembly has been correctly installed.

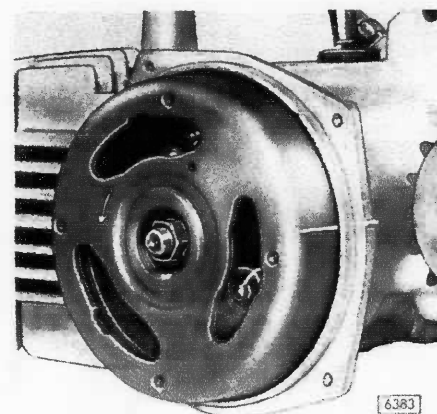

TROUBLE SHOOTING

ENGINE DOES NOT START OR IS HARD TO START

STEP 1 Ensure that on-off switch is in the on position

STEP 2 Check for fuel flow to carburetor

a. Depress primer button on carburetor and observe external fuel flow. If fuel flows, proceed to STEP 3.

If fuel does not flow:

b. remove fuel line from carburetor fitting, open fuel valve and watch for fuel flow. If fuel flows, proceed to STEP 4.

If fuel does not flow:

c. check fuel level in tank, if ok, clean tank and fuel valve filters.

d. attempt to start moped, if moped does not start, proceed to STEP 3.

STEP 3 Check for adequate spark.

a. Remove spark plug from cylinder head, place spark plug in the metal spark plug protector hold spark plug to ground on cylinder head and crank engine. Observe the spark – a crisp blue color is normal – orange color indicates ignition malfunction.

Be sure that there is no fuel leakage before making an external ignition test.

If a good strong blue spark is evident, proceed to STEP 4.

Weak or no spark;

b. replace the spark plug with a know good spark plug, crank the engine, if spark occurs, attempt to start.

Weak or no spark;

c. unscrew the plug protector from the hi-tension wire, hold the wire end appr. 1 in. (2 - 3 mm) from ground and crank the engine. If spark occurs, replace the spark plug protector.

Weak or no spark;

d. remove the blue-black wire from the terminal block (magneto side) and connect the exposed end with the green-black wire in the terminal block. Crank the engine, if spark occurs, the problem lies in the horn circuit. Check the continuity of the blue-black wire through the harness to the horn switch. (The wire may be broken in the harness at the steering head area),

If spark does not occur:

remove the black wire(s) from the terminal block. Crank the engine, if spark occurs, replace the on-off switch.

If spark does not occur:

e. check magneto function;

1. remove the blue-black wire from the terminal block where it was joined with the green-black. Temporarily leave disconnected.

2. remove the blue wire from the hi-tension coil.

TROUBLE SHOOTING

3. connect one lead of the Puch special point tester 905.6.28.601.0 to the blue wire end, and the other lead to ground.
4. remove the flywheel dust cover and slowly rotate the flywheel in the indicated direction of rotation.
5. observe the ohmmeter for a full scale fluctuation of the indicator needle, a closed reading with no movement of the needle indicates;
 - a. shorted points or condenser
 - b. closed points (check condition of rubbing block)
an open reading with no needle movement indicate;
 - a. open points
 - b. very high point resistance
 - c. broken blue wire

If full scale needle fluctuation is observed, check point resistance by rotating the flywheel until the needle fluctuates to the closed side of the scale, the reading should indicate in the red zone (less than .1 ohms resistance). With the needle in the closed position, remove the ohmmeter lead from ground and replace on the free end of the blue-black wire. The indicated reading will show ignition armature resistance (normal - .75 ohms).

REPAIRS:

1. closed points - adjust to specifications or replace if rubbing block worn
2. shorted points - check for shorts at attachment leads for internally shorted points - replace shorted condenser
3. open points - adjust to specifications
4. high point resistance - replace points (if blue and burned, replace condenser)
5. ignition armature resistance incorrect - replace armature.

After making any of the above repairs, retune the engine, and check for spark. If spark occurs, attempt to start the engine.

If spark does not occur:

check flywheel by cranking engine with light switch on, if headlight lights, flywheel is functional. If headlight does not light, replace flywheel.

Crank engine and check for spark. If spark occurs, attempt to start.

If spark does not occur:

replace the hi-tension coil with a know good one.

STEP 4 Timed spark occurs, fuel flows to carburetor, but the moped will not start;

- a. check starter clutch function
- b. check compression (cranking resistance)
- c. crank engine to attempt start; if engine does not start, remove spark plug and examine condition

If wet, remove carburetor fuel bowl and check

- a. fuel quality, i.e., (stale, water contamination, unknow liquid)
- b. excess oil in gasoline
- c. clogged air filter
- d. main jet wrong size or loose in bowl

If plug is dry, remove carburetor fuel bowl and check

- a. clogged main jet
- b. stuck float or needle (no fuel in bowl)
- c. clogged filter in banjo fitting

TROUBLE SHOOTING

OTHER COMMON COMPLAINTS

1. Lack of power; limited top speed

- a. dragging brakes
- b. tight chain
- c. under inflated tires
- d. defective spark plug
- e. clogged air filter
- f. clogged exhaust

g. choke not returning fully causing "4 stroking at top end"

- h. low float level
- i. main jet incorrect
- j. incorrect ignition timing

CORRECTION

adjust correctly
adjust to specifications
inflate to specifications
replace
clean or replace
de-carbon engine
de-carbon pipe and baffle
ensure that throttle cable is opening the choke slide fully. If throttle opens fully, bend the choke tab down where it contacts the throttle slide.
adjust to specifications
if plug is burning black, decrease size
adjust to specifications

MALFUNCTIONS IN LIGHTING CIRCUITS

The Puch moped is equipped with an A. C. magneto. The ultimate power generated by each circuit is limited only by the load on each circuit; there is no means of voltage limitation other than the bulbs in the circuit. It is therefore of the utmost importance to utilize only the bulb specified for each circuit.

The following tests, it is assumed that you have in your possession a Puch low scale ohmmeter 905.6.28.601.0.

I. The Tail Lamp Circuit

The tail lamp circuit is powered by the grey wire coming out of the magneto. The magneto armature for the circuit is internally grounded. The correct bulb size is 6 Volt, 5 Watt.

The taillight circuit is unique in that its on-off function is **not** directly controlled by the lighting switch. It is controlled by the headlight armature being energized, and in turn, by induction, energizing the tail lamp armature. Bear in mind that because of the design of the circuit that the tail lamp cannot function without the head lamp.

TROUBLE SHOOTING: inoperative taillight

- 1. ensure that the head lamp is working
- 2. check the bulb, both for burn out and proper size
- 3. check for adequate ground utilizing the Puch ohmmeter.
- 4. check for continuity in the fender harness (wires may rub through)
- 5. check for tail lamp armature resistance
disconnect the grey wire (magneto side) from the terminal block. Connect 1 lead of the ohm-meter to the grey wire and the other lead to ground. The correct resistance should be (6-7) ohms.

II. The Stop Light Circuit

The stop light circuit is powered by the solid green wire coming out of the magneto. The green-black wire is the ground for the brake light armature. It connects with the brown wire in the terminal block. The correct bulb is 6 Volt, 10 Watts.

The stop light circuit is a simple continuity circuit controlled by two switches, one at each grip.

TROUBLE SHOOTING: inoperative stop light

- 1. check the bulb for burn out and for proper size.

TROUBLE SHOOTING

2. check the ground circuit utilizing the Puch ohmmeter
3. check the switches utilizing the ohmmeter
With the leads connected to the two terminals of the switch, the ohmmeter should indicate a closed circuit when the lever is pulled. If not, replace the switch.
4. continuity of the wire from the terminal block to the switches and to the rear lamp can be checked with the ohmmeter.
5. check the stop light armature by disconnecting the green lead from the terminal block, connect 1 lead of the ohmmeter to green and other to ground. The proper reading is 1-1,2 ohms.

III. The Headlight Circuit

The headlight circuit powered by the yellow wire coming out of the magneto. The headlight armature is internally grounded. The correct bulb is 6 V, 21 Watt.

Proper resistance in the lighting circuit is maintained by having BOTH the leadlight and speedometer bulbs operative in the circuit. If one bulb fails, it is certain that after a period of time, the other will fail also.

When replacing a headlight bulb, be sure that the speedometer bulb is operative.

Accessory directional signal can be tied to the head lamp circuit. The easiest and neatest place to connect is at the head lamp switch at the terminal where the yellow wire comes in to the switch.

TROUBLE SHOOTING: inoperative headlight

1. check the bulb for burn out and for proper size.
2. check the switch by connecting the ohmmeter to the terminals at the back of the switch; one lead to the yellow wire and one lead to the yellow-black wire. With the switch turned on, the ohmmeter should indicate a closed circuit.
3. check the headlight armature by removing yellow from terminal block. Connect 1 lead of the ohmmeter to yellow and the other to ground. The reading should be 2. ohms.

TROUBLE SHOOTING: units which 6 V regulator

1. No lights at higher engine RPM:
Disconnect regulator. If light is operating bright at all different engine RPM same, short circuit in regulator. Replace regulator.
2. Blowing bulbs at high engine RPM:
Disconnect regulator. Start engine and run at high engine RPM. Lights should become dimmer if regulator is connected to light system. If this is not the case, regulator faulty. Replace regulator.

NOTE: This regulator may also be used on older MAXI and MAGNUM series if blowing light bulb problem can not be cured.

TROUBLE SHOOTING

POOR PERFORMANCE

1. Ignition timing off – adjust ignition timing as per “Service Manual”
2. Brakes drag – adjust brake cables
3. Wrong cylinder/piston match – refer to sorting table on page 41.
4. Throttle slide does not open fully – check throttle cable for damage (fried) and/or adjustment. Check for faulty choke slide.

EXCESSIVE SMOKING

1. Wrong gas/oil mixture – a) drain fuel and fill tank with correct mixture, refer to “Technical Data” MAGNUM MK II, drain fuel and fill tank with pure gasoline only.
b) replace defective right side crankshaft seal, refer to page 43, 62.

ENGINE RACING OR NO IDLE

1. Carburetor loose – push carburetor fully onto the intake pipe (manifold) and secure same on it.

ENGINE RACING OR NO IDLE

1. Carburetor loose – push carburetor fully onto the intake pipe (manifold) and secure same on it.
2. Manifold loose – check vacuum leak on manifold flange or gasket. Tighten manifold to cylinder and/or replace flange gasket.
3. Leaking seal – replace defective seal on generator side.
4. Throttle stop – adjust engine idle speed with throttle stop screw. Ensure that preliminary adjustments, such as timing, throttle cable slack, have been carried out.

Shortcomings of the following nature may be found on the one- or two-speed automatic:

ENGINE MAY BE DIFFICULT TO CRANK

1. Starting clutch slips – a) adjust starter cable. One speed automatic refer to page 49-52. Two speed automatic refer to page 79.
b) drain transmission oil and fill transmission with ATF “TYPE F”. Visual check of the oil may not reveal if ordinary engine oil or ATF is filled.
c) worn clutch lining, replace. The excessive wear of the clutch lining on the starting clutch is caused by improper adjusted starter cable or by applying clutch while riding machine.

Shortcoming which may occur on the two-speed-automatic:

TRANSMISSION SHIFTING

1. No neutral – seized bushing on the crankshaft/clutch drum, refer to page 58-62.
2. Does not shift into 2nd gear – defective free wheel on first gear, replace defective parts of freewheel. Refer to page 75 for additional information.
3. No first gear – free wheel rollers not installed correctly. Ref. to page 75 for correct installation.

WIRING DIAGRAM

WIRING DIAGRAM

- 1) Headlamp
- 2) Speedometer bulb (Maxi "S" only)
- 3) Bulb resistor
- 4) Stop switch
- 5) Light switch
- 6) Horn
- 7) Brake light switch
- 8) Brake light switch
- 9) Flywheel magneto
- 10) Ignition coil
- 11) Spark plug
- 12) Tail stop license/plate

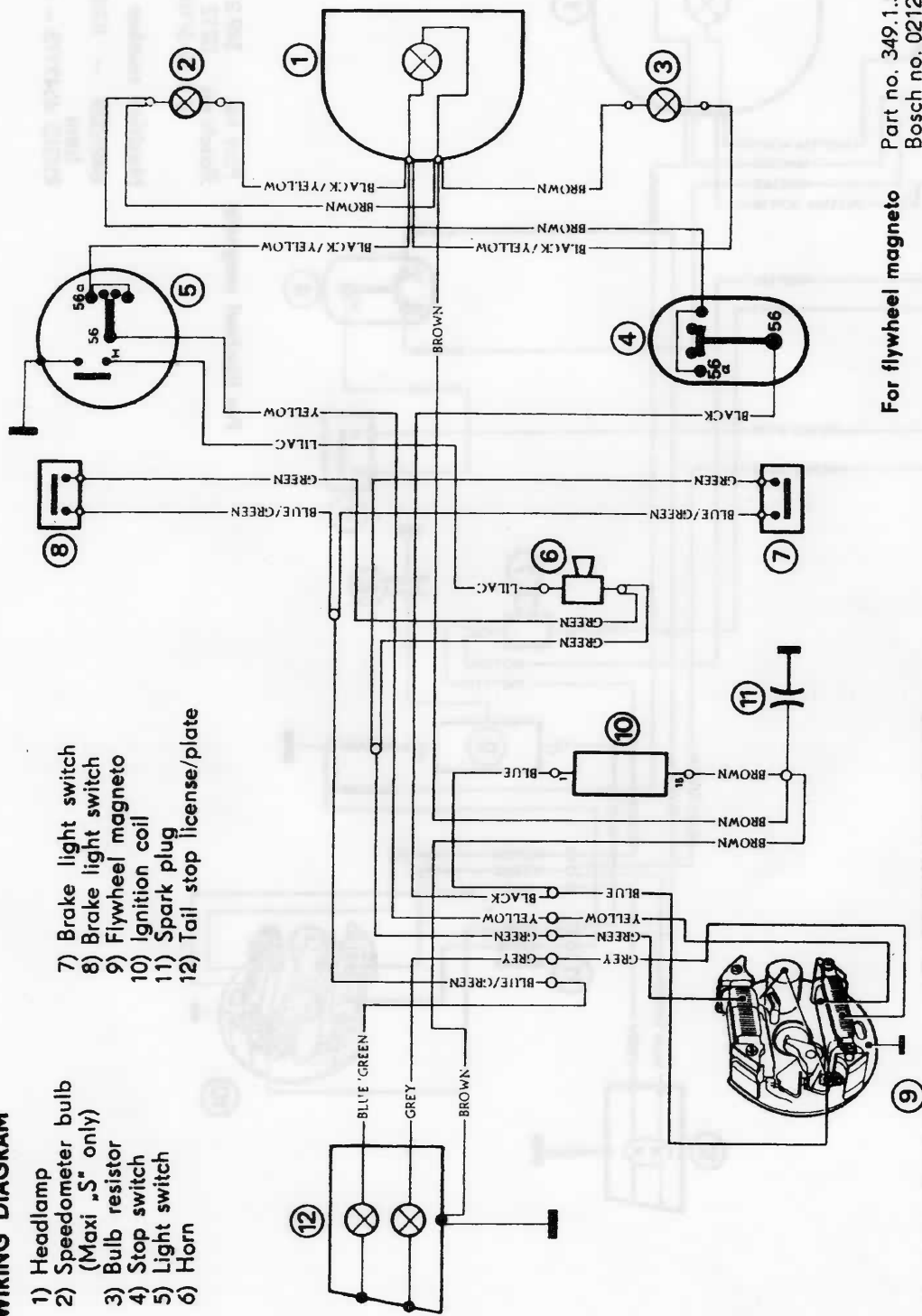

For flywheel magneto Part no. 349.1.50.800.0
 Bosch no. 0212 124 038
 (6 V 22-5/18 W)

Machine number
 8353263 - 8421028
 from to
 RIGID 6539521 - 6547172

WIRING DIAGRAM

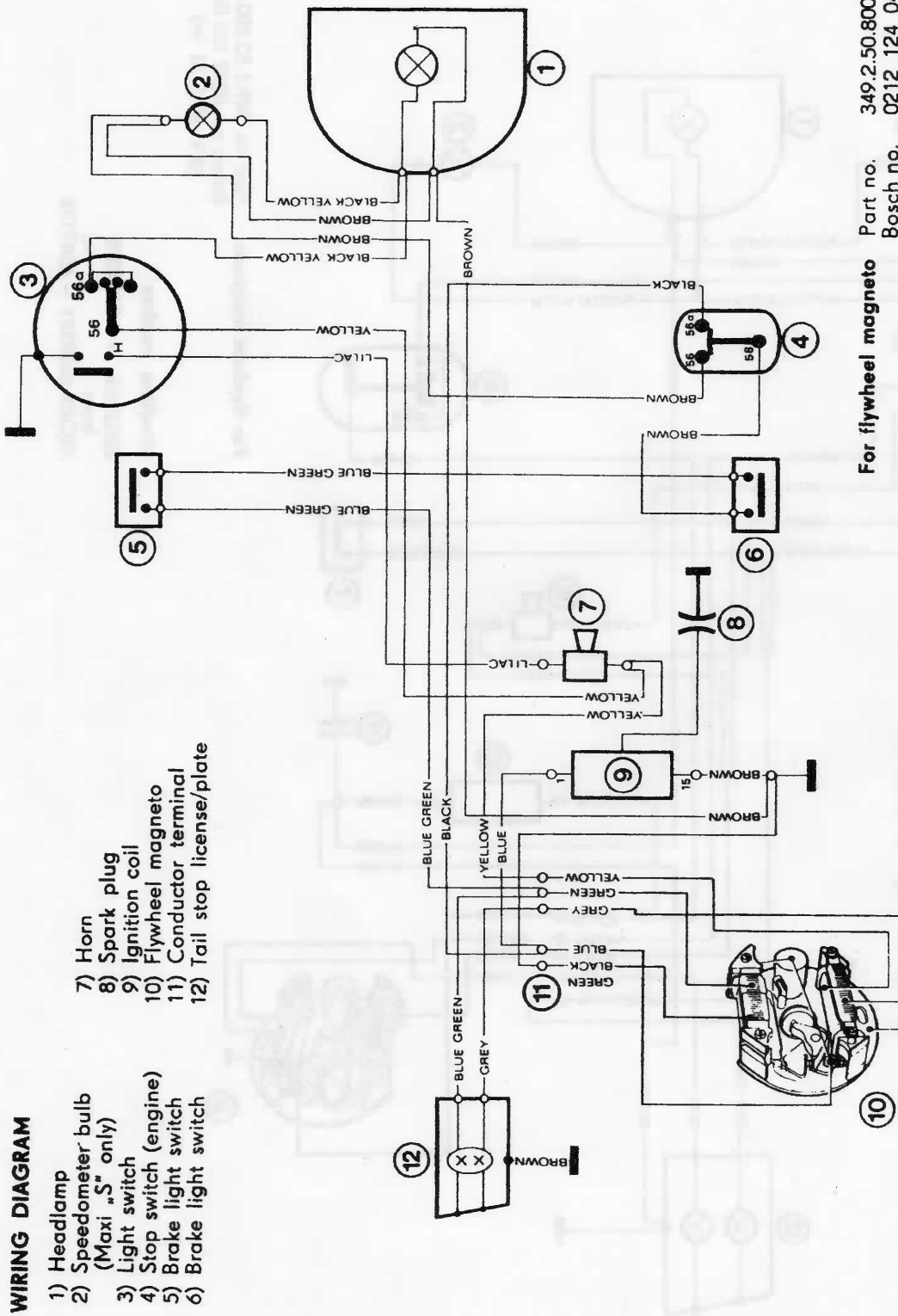

For flywheel magneto Part no. 349.2.50.800.0
 Bosch no. 0212 124 042
 (6 V 22-5/10 W)

Machine number
 8421029 -- 8709891
 from to
 RIGID 6547173 -- 6830115

WIRING DIAGRAM

WIRING DIAGRAM - MAXI, MAXI LUXE

- 1) Headlamp
- 2) Speedometer bulb
- 3) Light switch/Horn button
- 4) Engine stop switch
- 5) Brake light switch
- 6) Brake light switch
- 7) Horn
- 8) Spark plug
- 9) Ignition coil
- 10) Generator 6 V, 26-5/10 W
- 11) Wire connector
- 12) Tail/Stop light

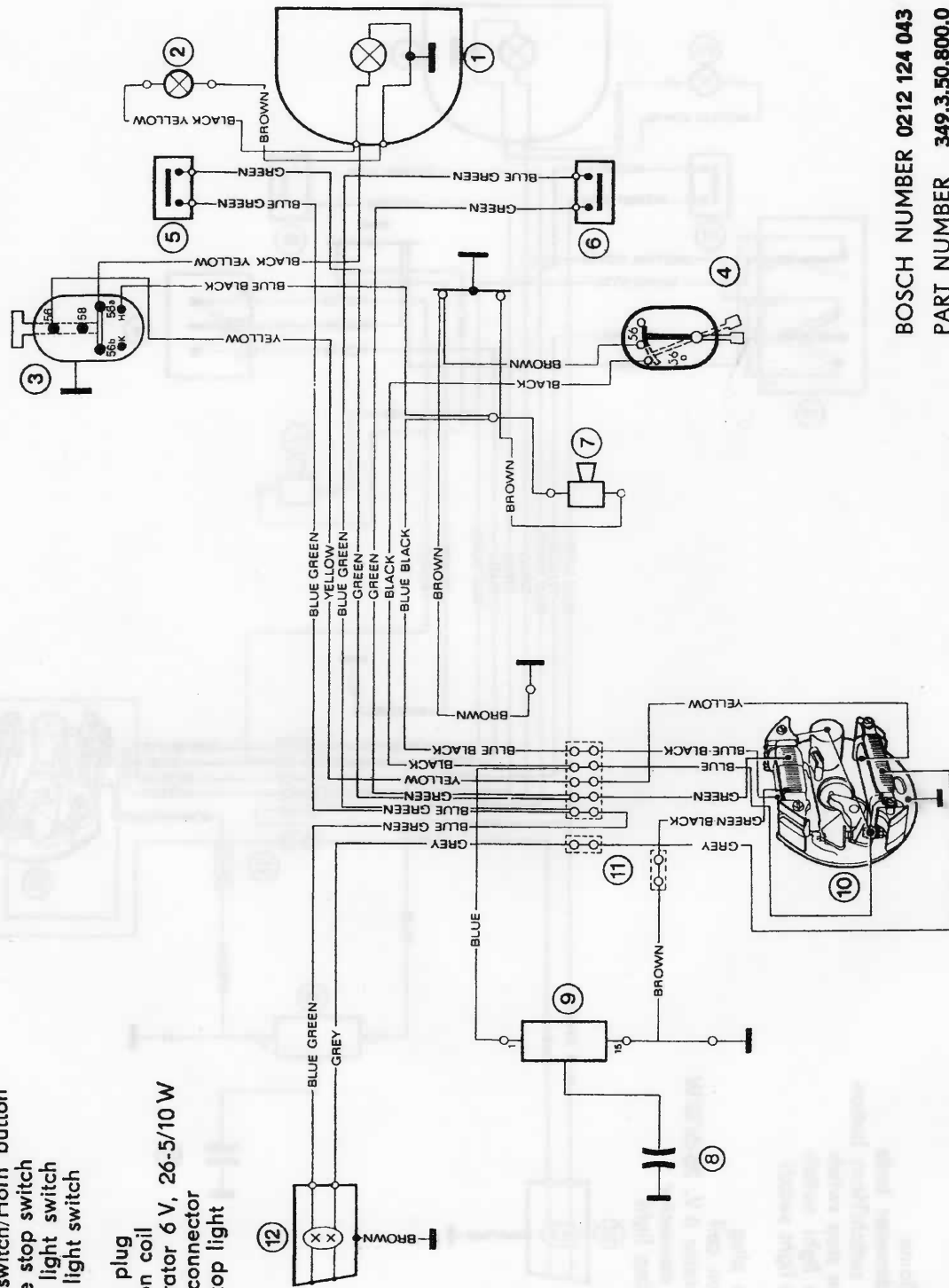

BOSCH NUMBER 0212 124 043
PART NUMBER 349.3.50.800.0

WIRING DIAGRAM

WIRING DIAGRAM – NEWPORT II, SPORT MK II

- 1) Headlamp
- 2) Speedometer bulb
- 3) Light switch/Horn button
- 4) Engine stop switch
- 5) Brake light switch
- 6) Brake light switch
- 7) Horn
- 8) Spark plug
- 9) Ignition coil
- 10) Generator 6 V, 26-5/10 W
- 11) Wire connector
- 12) Tail/Stop light

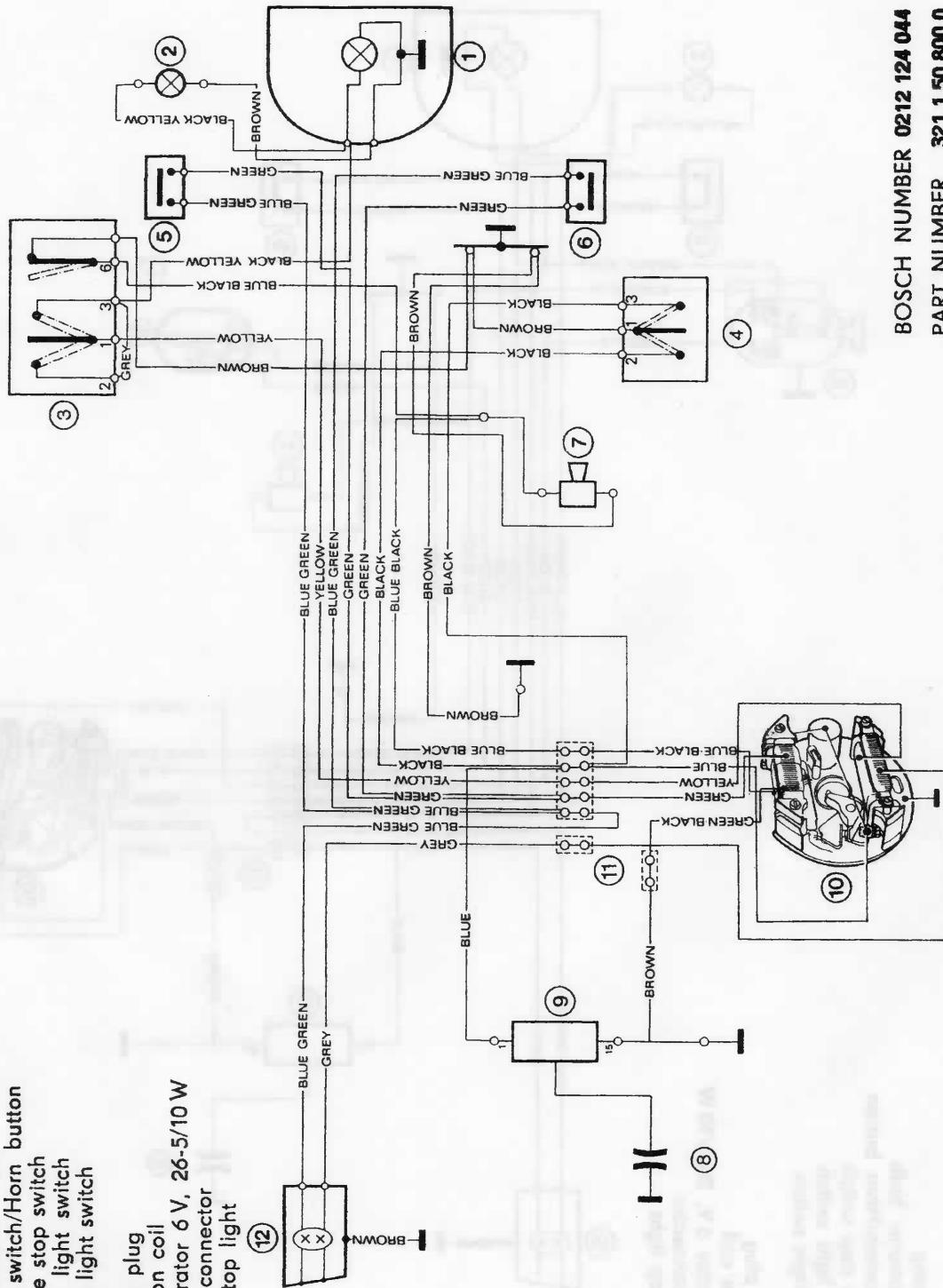

BOSCH NUMBER 0212 124 044
PART NUMBER 321.1.50.800.0

WIRING DIAGRAM

WIRING DIAGRAM - MAGNUM II

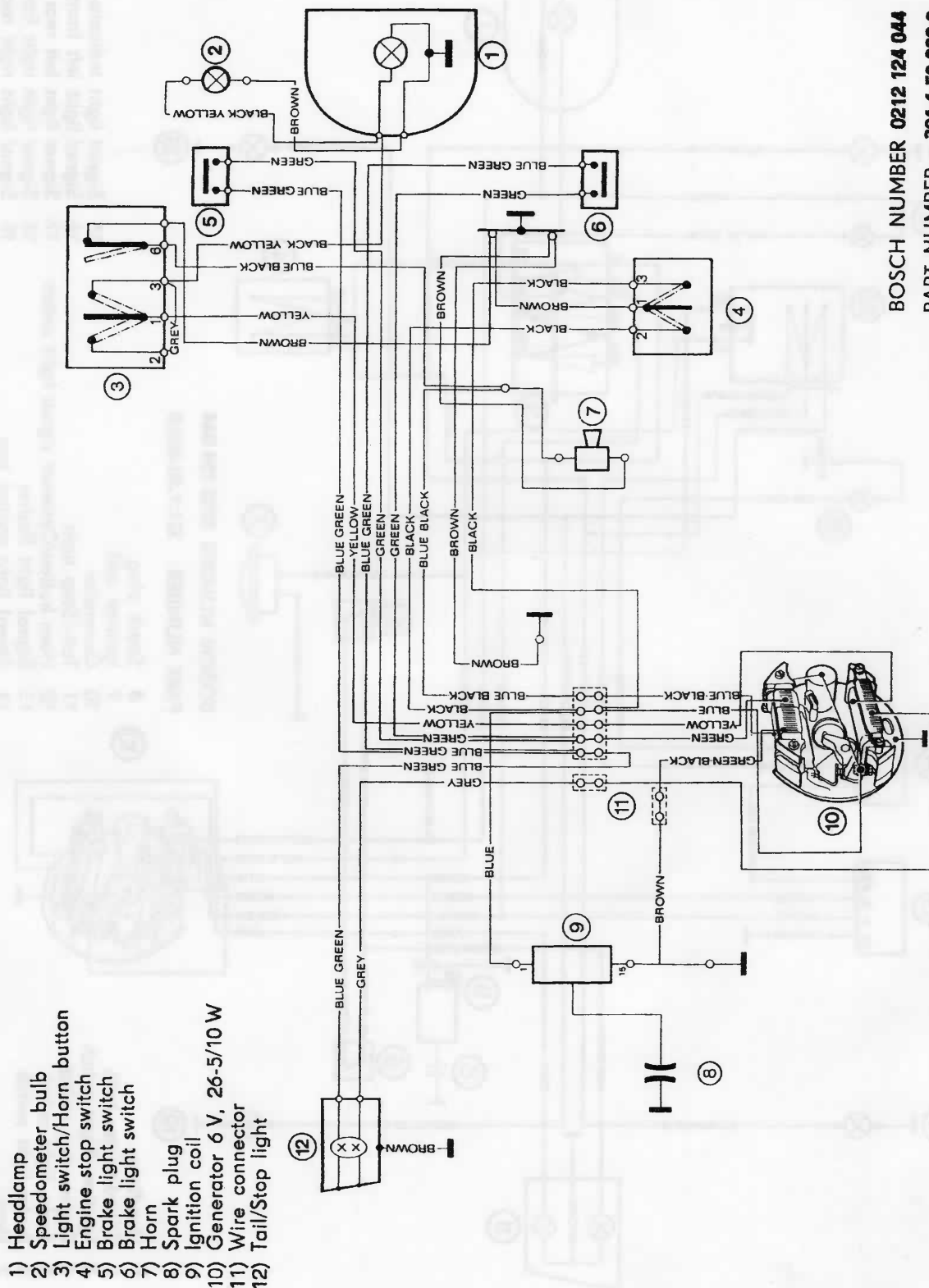

- 1) Headlamp
- 2) Speedometer bulb
- 3) Light switch/Horn button
- 4) Engine stop switch
- 5) Brake light switch
- 6) Brake light switch
- 7) Horn
- 8) Spark plug
- 9) Ignition coil
- 10) Generator 6 V, 26-5/10 W
- 11) Wire connector
- 12) Tail/Stop light

BOSCH NUMBER 0212 124 044
PART NUMBER 321.1.50.800.0

WIRING DIAGRAM

WIRING DIAGRAM -- MAGNUM MK II

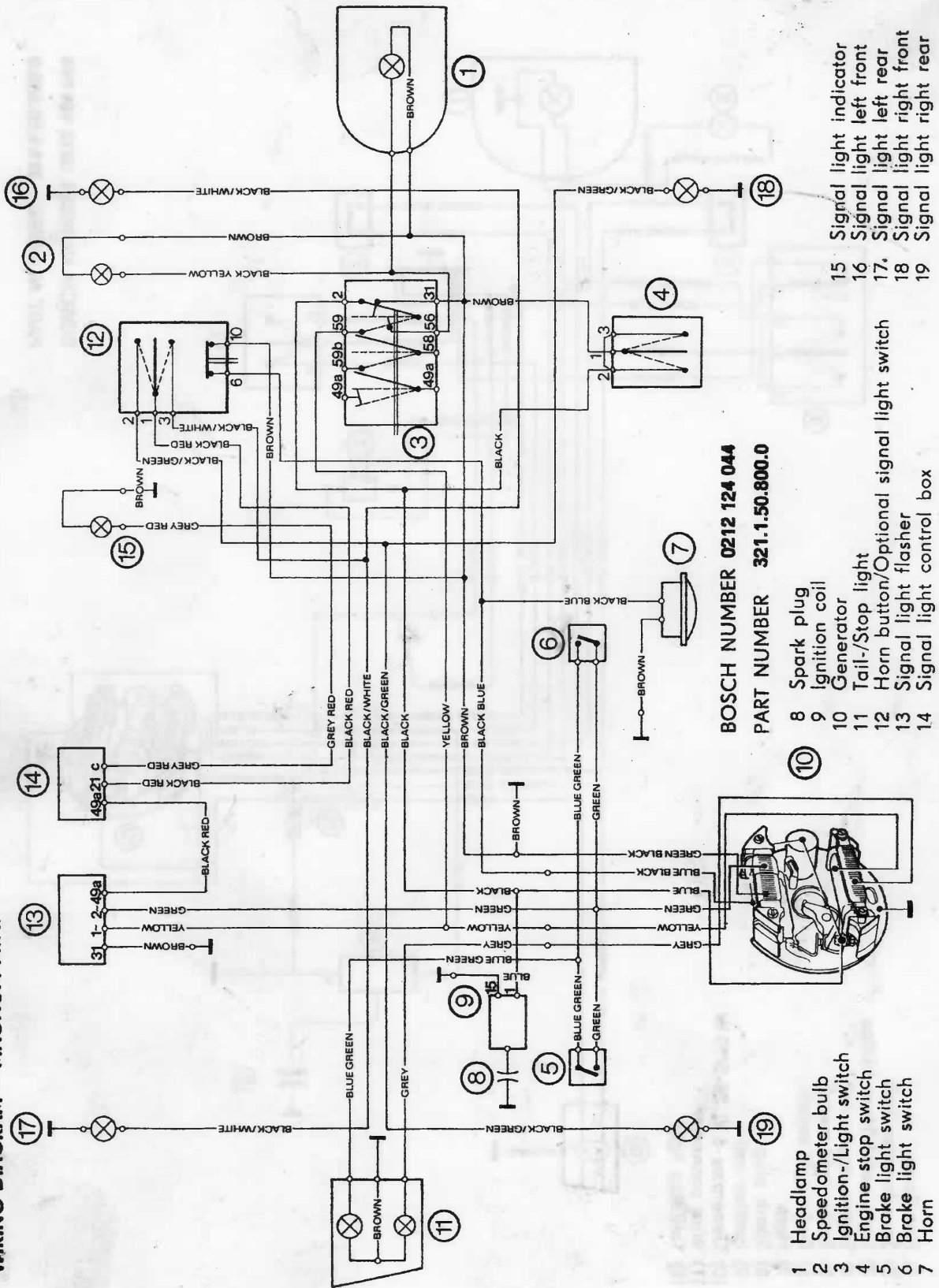

- 1 Headlamp
- 2 Speedometer bulb
- 3 Ignition-/Light switch
- 4 Engine stop switch
- 5 Brake light switch
- 6 Brake light switch
- 7 Horn

- 8 Spark plug
- 9 Ignition coil
- 10 Generator
- 11 Tail-/Stop light
- 12 Horn button/Optional signal light switch
- 13 Signal light flasher
- 14 Signal light control box

- 15 Signal light indicator
- 16 Signal light left front
- 17. Signal light left rear
- 18 Signal light right front
- 19 Signal light right rear

WIRING DIAGRAM

**WIRING DIAGRAM - MAXI SPORT LS 123
COBRA (WITHOUT No. 9, Regulator)**

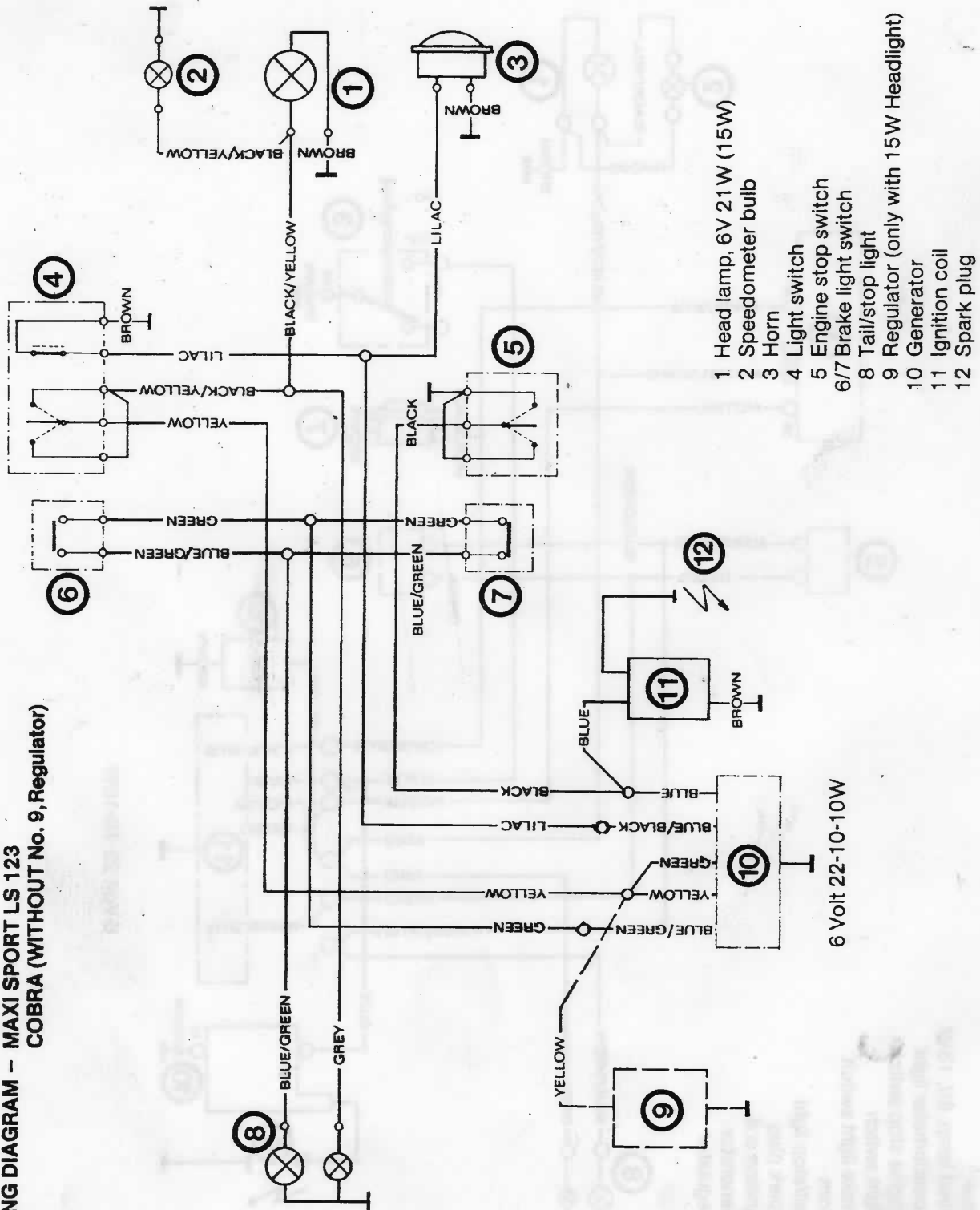

WIRING DIAGRAM

WIRING DIAGRAM - DART

- 1 Head lamp, 6V, 15W
- 2 Speedometer light
- 3 Engine stop switch
- 4 Light switch
- 5/6 Brake light switch
- 7 Horn
- 8 Tail/stop light
- 9 Spark plug
- 10 Ignition coil
- 11 Generator
- 12 Regulator

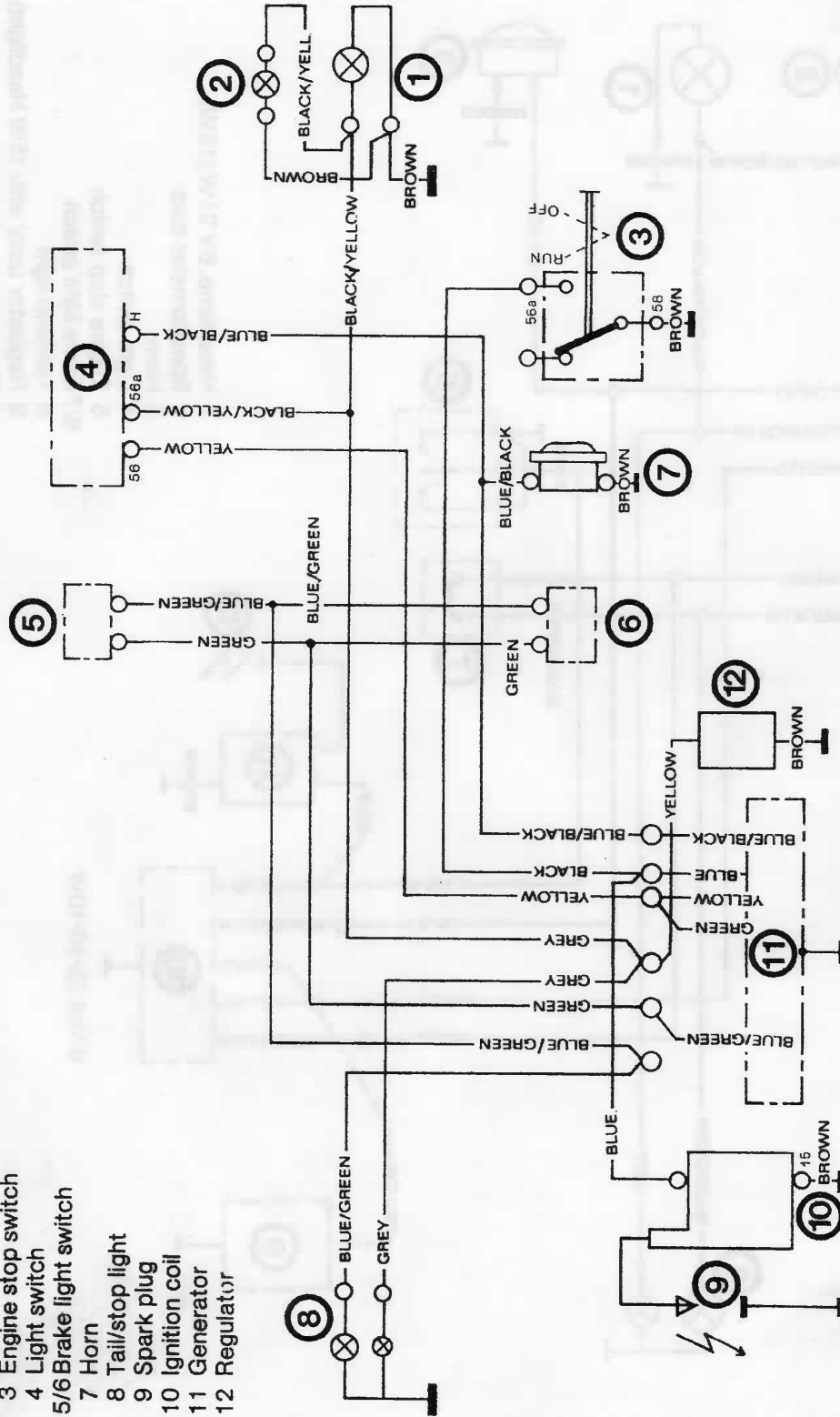

6 Volt 22-10-10W

WIRING DIAGRAM

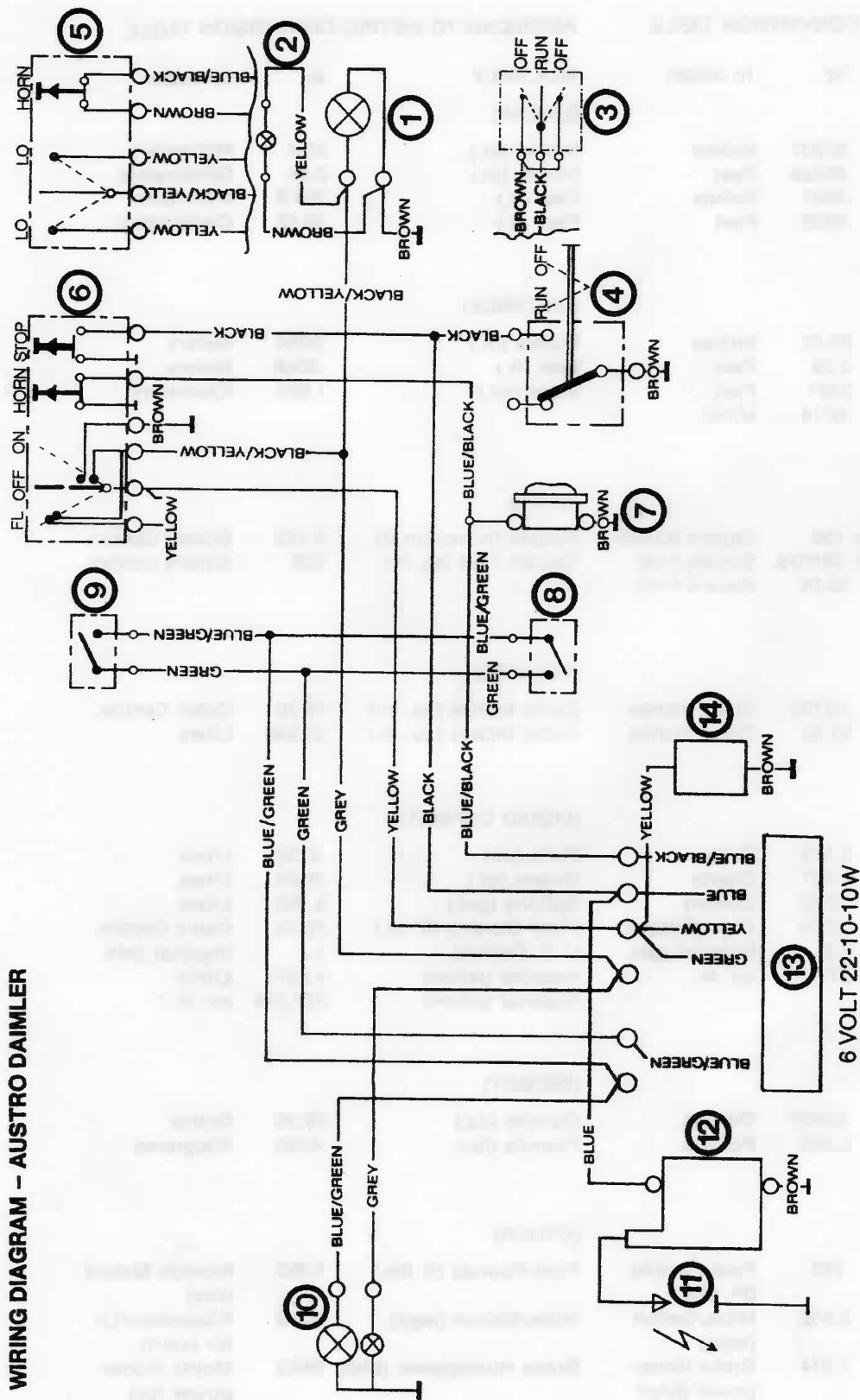

- | | | | |
|---|--------------------|----|--------------------|
| 1 | Headlamp | 8 | Brake light switch |
| 2 | Speedometer bulb | 9 | Brake light switch |
| 3 | Engine stop switch | 10 | Tail/stop light |
| 4 | Engine stop switch | 11 | Spark plug |
| 5 | Light/horn switch | 12 | Ignition coil |
| 6 | Light/horn switch | 13 | Generator |
| 7 | Horn | 14 | Regulator |

WIRING DIAGRAM - AUSTRO DAIMLER

METRIC CONVERSION TABLE

METRIC TO AMERICAN CONVERSION TABLE

MULTIPLY	by	to obtain
(LINEAR)		
Millimeters (mm)	.03937	Inches
Millimeters (mm)	.00328	Feet
Centimeters (cm)	.3937	Inches
Centimeters (cm)	.0328	Feet
(DISTANCE)		
Meters (m)	39.37	Inches
Meters (m)	3.28	Feet
Kilometers (km)	3281	Feet
Kilometers (km)	.6214	Miles
(AREA)		
Square Centimeters (cm ²)	.155	Square Inches
Square Centimeters (cm ²)	.001076	Square Feet
Square Meters (m ²)	10.76	Square Feet
(VOLUME)		
Cubic Centimeters (cc)	.06102	Cubic Inches
Liters (l)	61.02	Cubic Inches
(LIQUID CAPACITY)		
Liters (l)	2.113	Pints
Liters (l)	1.057	Quarts
Liters (l)	.2642	Gallons
Cubic Centimeters (cc)	.0338	Fluid Ounces
U. S. Gallons	1.2	Imperial gals.
Imperial Gallons	277.274	cu. in.
(WEIGHT)		
Grams (gm)	.03527	Ounces
Kilograms (kg)	2.205	Pounds
(OTHER)		
Newton Meters (Nm)	.723	Foot Pounds (Ft. Lbs.)
Kilometers/Liters (km/l)	2.352	Miles/Gallon (mpg)
Metric Horsepower (ps)	1.014	Brake Horsepower (bhp)

AMERICAN TO METRIC CONVERSION TABLE

MULTIPLY	by	to obtain
(LINEAR)		
Inches (in.)	25.4	Millimeters
Inches (in.)	2.54	Centimeters
Feet (ft.)	304.8	Millimeters
Feet (ft.)	30.48	Centimeters
(DISTANCE)		
Inches (in.)	.0254	Meters
Feet (ft.)	.3048	Meters
Miles (mi.)	1.609	Kilometers
(AREA)		
Square Inches (in. 2)	6.452	Square Centim.
Square Feet (sq. ft.)	929	Square Centim.
(VOLUME)		
Cubic Inches (cu. in.)	16.39	Cubic Centim.
Cubic Inches (cu. in.)	.01639	Liters
(LIQUID CAPACITY)		
Pints (pt.)	.4732	Liters
Quarts (qt.)	.9463	Liters
Gallons (gal.)	3.785	Liters
Fluid Ounces (fl. oz.)	29.58	Cubic Centim.
U. S. Gallons	1.2	Imperial gals.
Imperial gallons	4.537	Liters
Imperial gallons	277.274	cu. in.
(WEIGHT)		
Ounces (oz.)	28.35	Grams
Pounds (lb.)	.4536	Kilograms
(OTHER)		
Foot-Pounds (ft. lbs.)	1.383	Newton Meters (Nm)
Miles/Gallon (mpg)	.4252	Kilometers/Liter (km/l)
Brake Horsepower (bhp)	.9862	Metric Horsepower (ps)

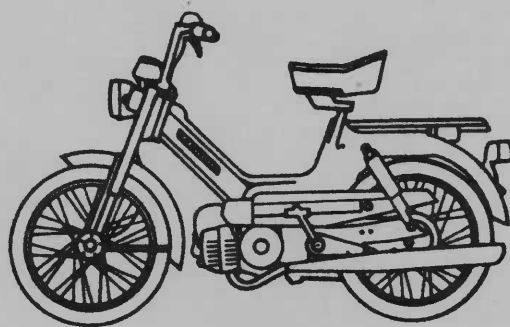

SALES • SERVICE • PARTS • ACCESSORIES
